

38-DIS-1RS6 S



Specifications:

DIAMETER	38 mm
NECK FINISH	38-400
CLOSURE TYPE	Dispensing
CLOSURE TOP	Smooth Flip-Top
CLOSURE SIDEWALL	Ribbed
ORIFICE	Slotted
MATERIAL	PP

PACKAGING & FREIGHT INFORMATION

PACK TYPE	PCS/CTN	CTNS/PALT	PCS/PALT	CTN WT*	PALT WT*	FRT CLASS
Bulk	2,250	15	33,750	29.5 ⁽¹⁾	442 ⁽¹⁾	110 ⁽¹⁾
Bulk	2,250	15	33,750	31 ⁽²⁾	463 ⁽²⁾	110 ⁽²⁾
CARTON DIMENSIONS: 24 x 16 x 15			PALLET DIMENSIONS: 48 x 40 x 50			

(1) Unlined Closures (2) Lined Closures *Approximate

MARKETS

Food, Condiments, Dressings & Sauces, Jams & Jellies, Honey, Cleaning Products, Lotions, Home Care, Personal Care

OPTIONS

Available in white, standard, and custom colors. Can be lined with a wide variety of liner systems.

CLOSURE BENEFITS

- Popular for mayonnaise and jelly
- MESA flip-top dispensing closure
- Easy dispensing & clean flow
- Audible “click” indicates security
- Single-wall design

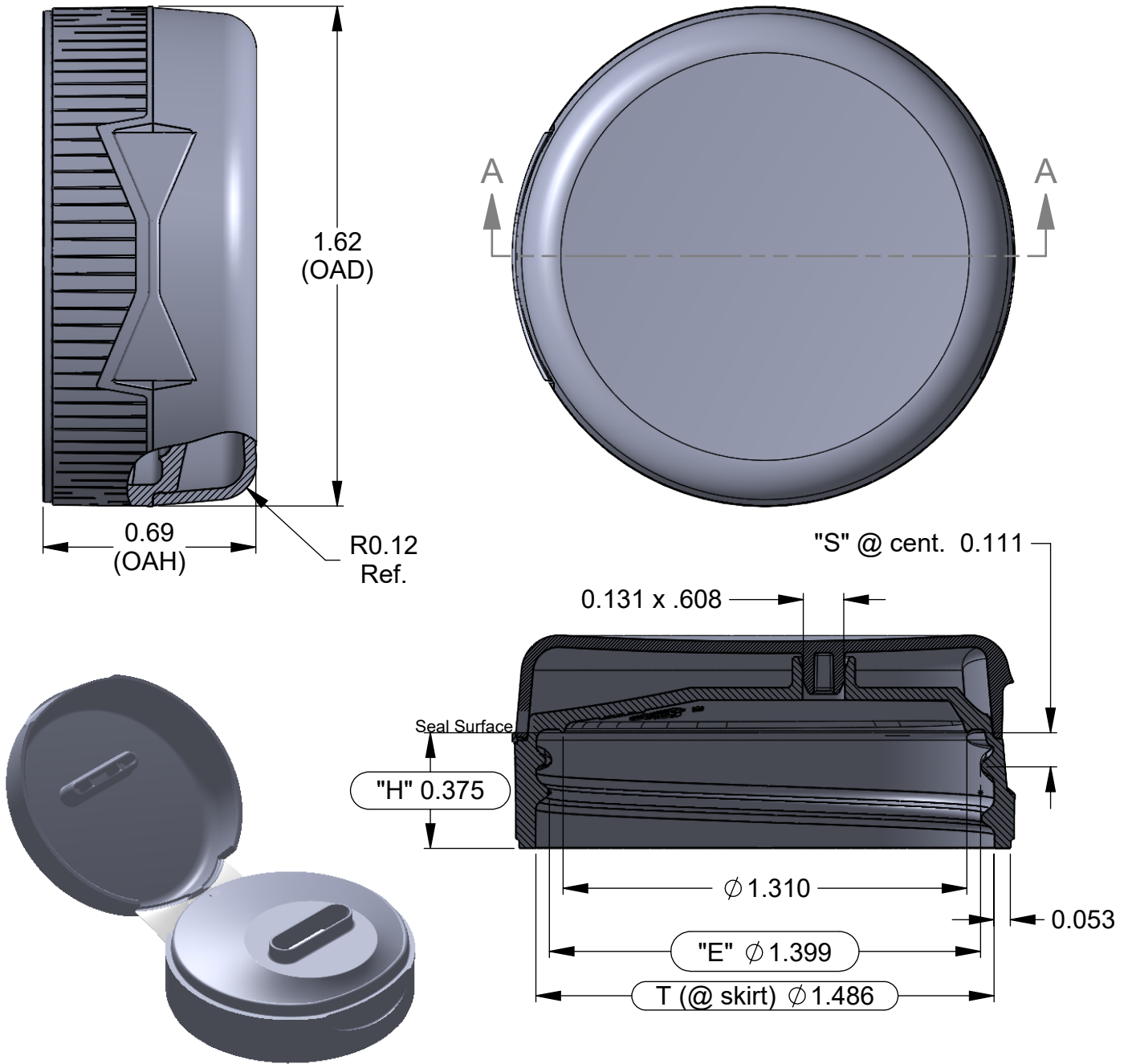

NOTES: (UNLESS OTHERWISE SPECIFIED) 1. ALL DIMENSIONS ARE IN INCHES. 2. GENERAL TOLERANCING: ± 0.010 THIS OR FACSIMILE THEREOF IS THE EXCLUSIVE PROPERTY OF PHOENIX CLOSURES, INC. AND MAY NOT BE REPRODUCED WITHOUT THE EXPRESS WRITTEN CONSENT OF PHOENIX CLOSURES, INC. SOME OR ALL OF THE ITEMS DEPICTED ON THIS DRAWING MAY BE COVERED BY CURRENT PATENTS OR PATENTS APPLIED FOR BY PHOENIX CLOSURES, INC.	R6	07.26.21	ALIGN SEAL SIZES TO PRODUCTION DATA	TCS			
	REV	DATE	DESCRIPTION	ECN BY			
	PRODUCT 038 - DIS - 1RS6 - S						
	DESC. MESA DISPENSING CLOSURE SLOT ORIFICE				DWG SIZE A		
	SPI FINISH	DRAWN BY	DRAWN DATE	TPI	TURNS	MATERIAL	SCALE
038-400	TCS	09.10.25	6	1	PP	2:1	CS

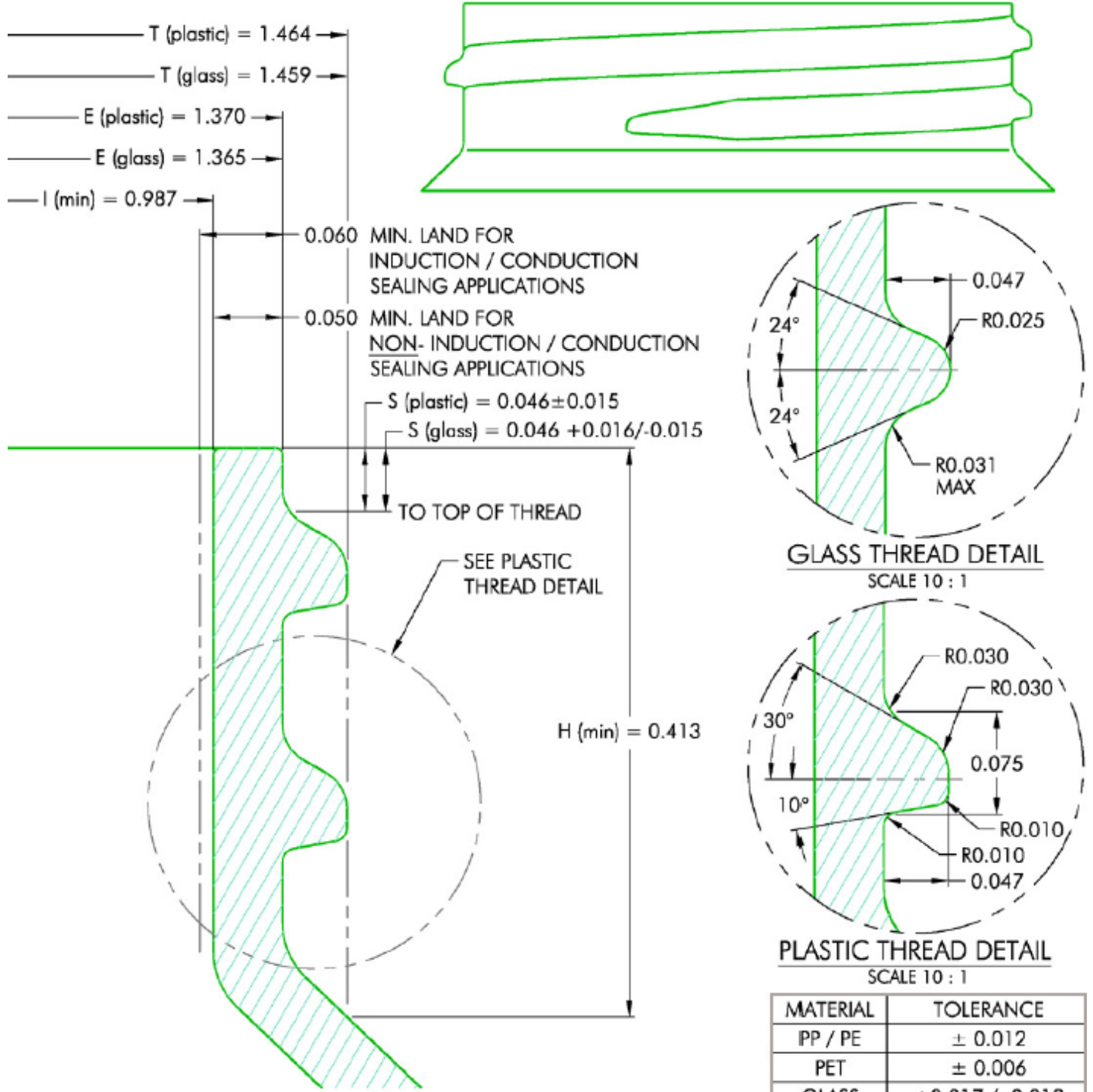

NOTES: (UNLESS OTHERWISE SPECIFIED)
 1. ALL DIMENSIONS ARE IN INCHES.
 2. SEE CHART FOR DIMENSIONAL TOLERANCE.

BF	05.21.18	Released	DN
REV	DATE	DESCRIPTION	BY
TOLERANCE	PITCH/TPI	1.67 / 6	TURNS 1-1/4
MAT'L	Per Chart		
.X	± 0.1	DRAWN BEZ	DATE 08.31.93
.XX	± 0.02	SCALE 10 : 1	REV
.XXX	± 0.010	38 - 400 - FINISH	0

THIS OR FACSIMILE THEREOF IS THE EXCLUSIVE PROPERTY OF PHOENIX AND MAY NOT BE REPRODUCED WITHOUT THE EXPRESSED WRITTEN CONSENT OF PHOENIX. SOME OR ALL OF THE ITEMS DEPICTED ON THIS DRAWING MAY BE COVERED BY CURRENT PATENTS OR PATENTS APPLIED FOR BY PHOENIX.



PHXPKG.COM

P 630 420 4750 E greatpkg@phxpkg.com
 975 Meridian Lake Drive • Aurora, IL 60504