

MEDIUM & DEEP SKIRTED CLOSURES

70-TAB-9901 S



Specifications:

DIAMETER 70 mm
THREAD PROFILE TAB
NECK FINISH 70-TAB
CLOSURE TOP Stipple
CLOSURE SIDEWALL: Broad Ribbed
MATERIAL PP

PACKAGING & FREIGHT INFORMATION

PACK TYPE	PCS/CTN	CTNS/PALT	PCS/PALT	CTN WT*	PALT WT*	FRT CLASS
Stack	800**	15	12,000	19 ⁽¹⁾	291 ⁽¹⁾	150 ⁽¹⁾
Stack	800**	15	12,000	21 ⁽²⁾	317 ⁽²⁾	125 ⁽²⁾
Bulk	725***	15	10,875	xx ⁽¹⁾	xxx ⁽¹⁾	xxx ⁽¹⁾
Bulk	725***	15	10,875	xx ⁽²⁾	xxx ⁽²⁾	xxx ⁽²⁾
CARTON DIMENSIONS: 24 x 16 x 15			PALLET DIMENSIONS: 48 x 40 x 50			

(1) Unlined Closures (2) Lined Closures *Approximate **FOB Newport, TN ***FOB Greencastle, IN

MARKETS

Dressings & Sauces, Food, Food Service, Peanut Butter & Nuts, and Powdered Drinks.

CLOSURE BENEFITS

- Broad-ribbed sides are easier to grip
- Popular for peanut butter and nuts

OPTIONS

Available in white, standard colors and custom colors. Can be lined with a wide variety of liner systems including SureSeal (foam), pressure sensitive and heat induction (foil) liners. Can be embossed/debossed with custom message. Offset printing is available in up to four colors.

MEDIUM & DEEP SKIRTED CLOSURES

70-TAB-9901 S

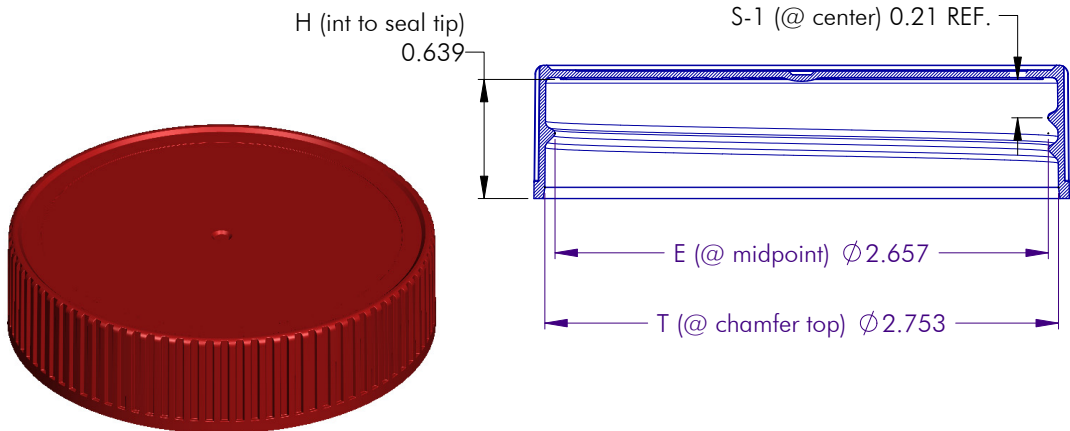
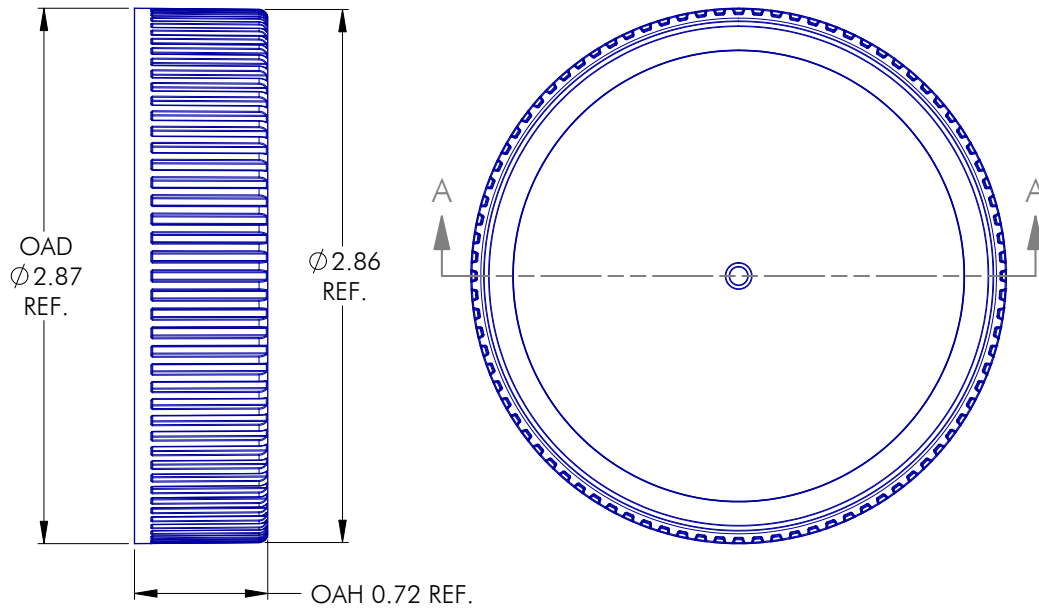

NOTES: (UNLESS OTHERWISE SPECIFIED) 1. ALL DIMENSIONS ARE IN INCHES. 2. SEE CHART FOR DIMENSIONAL TOLERANCE.		0	08.21.09	Released	DN
REV	DATE	DESCRIPTION			BY
TOLERANCE .X ±0.1 .XX ±0.02 .XXX ±0.010		PITCH/TPI	.167 / 6	TURNS	1-1/4
THIS OR FACSIMILE THEREOF IS THE EXCLUSIVE PROPERTY OF PHOENIX AND MAY NOT BE REPRODUCED WITHOUT THE EXPRESSED WRITTEN CONSENT OF PHOENIX. SOME OR ALL OF THE ITEMS DEPICTED ON THIS DRAWING MAY BE COVERED BY CURRENT PATENTS OR PATENTS APPLIED FOR BY PHOENIX.		MAT'L	PP		REV
		DRAWN	DMN	DATE	08.21.09
		SCALE	1-1/4 : 1		0
70 - TAB - 9901 S					

MEDIUM & DEEP SKIRTED CLOSURES

70-TAB-9901 S

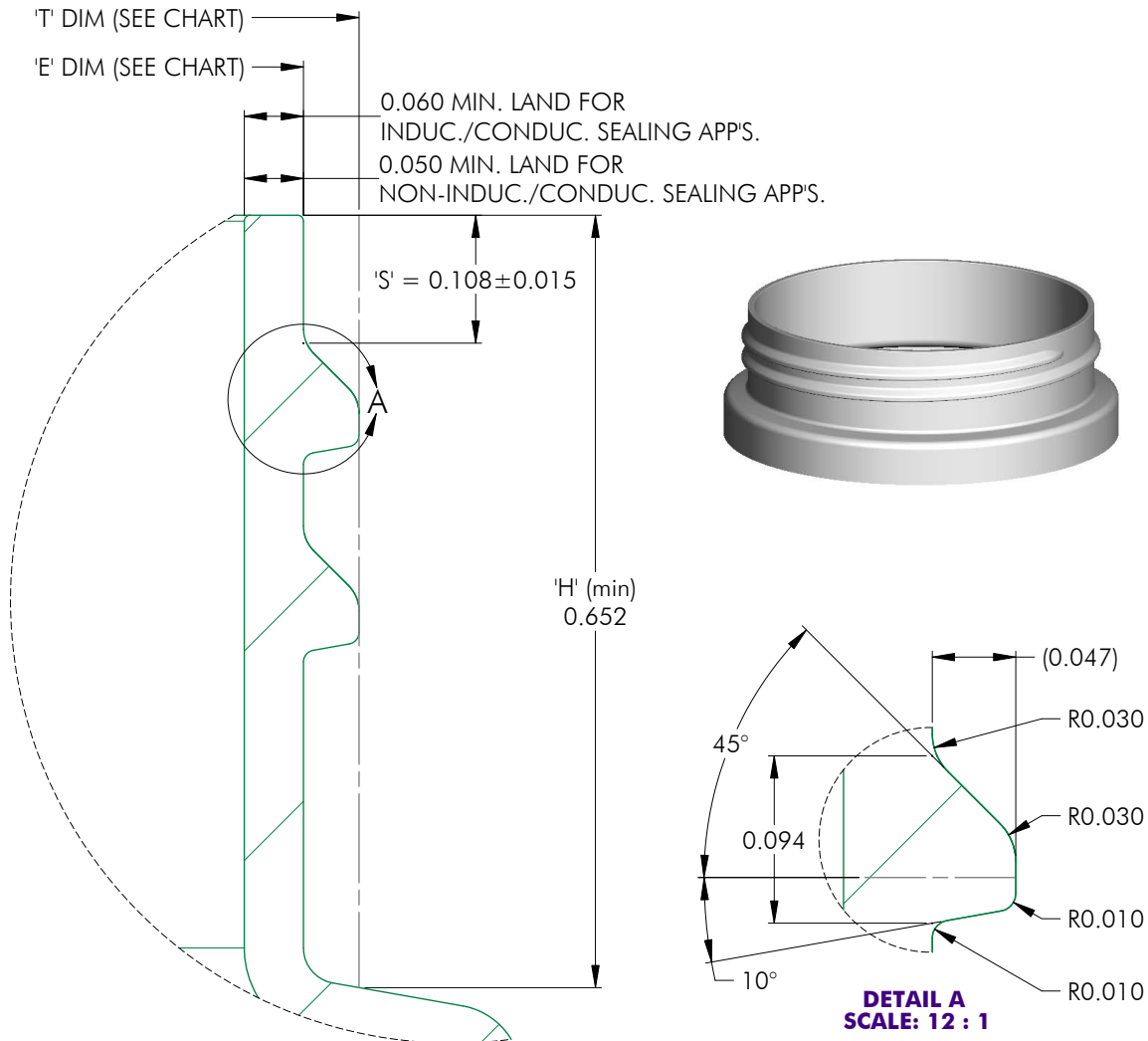

MATERIAL	T (mean)	E (mean)	TOLERANCE
PP / PE	2.7205	2.6265	± 0.0175
PET	2.726	2.632	± 0.012
GLASS	N/A	N/A	± N/A

NOTES: (UNLESS OTHERWISE SPECIFIED) 1. ALL DIMENSIONS ARE IN INCHES. 2. SEE CHART FOR DIMENSIONAL TOLERANCE.		1	11.28.01	Update "S" & Number of Turns	BZ					
THIS OR FACSIMILE THEREOF IS THE EXCLUSIVE PROPERTY OF PHOENIX AND MAY NOT BE REPRODUCED WITHOUT THE EXPRESSED WRITTEN CONSENT OF PHOENIX. SOME OR ALL OF THE ITEMS DEPICTED ON THIS DRAWING MAY BE COVERED BY CURRENT PATENTS OR PATENTS APPLIED FOR BY PHOENIX.		REV	DATE	DESCRIPTION	BY					
		TOLERANCE	PITCH/TPI	6 / 0	TURNS	1-1/2	MAT'L	PER CHART		
		.X	±0.1	DRAWN	DMN	DATE	03.20.97	SCALE	8 : 1	REV
		.XX	±0.02	70 - TAB - FINISH				1		
.XXX	±0.010									