

MEDIUM & DEEP SKIRTED CLOSURES

70-470-9620 S



Specifications:

- DIAMETER 70 mm
- THREAD PROFILE 470
- NECK FINISH 70-470
- CLOSURE TOP Stipple
- CLOSURE SIDEWALL: Fine Ribbed
- MATERIAL PP

PACKAGING & FREIGHT INFORMATION

PACK TYPE	PCS/CTN	CTNS/PALT	PCS/PALT	CTN WT*	PALT WT*	FRT CLASS
Stacked	900	15	13,500	21 ⁽¹⁾	313 ⁽¹⁾	125 ⁽¹⁾
Stacked	900	15	13,500	23 ⁽²⁾	339 ⁽²⁾	125 ⁽²⁾
CARTON DIMENSIONS: 24 x 16 x 15			PALLET DIMENSIONS: 48 x 40 x 50			

(1) Unlined Closures (2) Lined Closures *Approximate

MARKETS

Dressings & Sauces, Food, Food Service, Peanut Butter & Nuts, and Powdered Drinks.

CLOSURE BENEFITS

- Fine-ribbed sides are easier to grip
- Popular for mayonnaise products & dressings, peanut butter & nuts

OPTIONS

Available in white, standard colors and custom colors. Can be lined with a wide variety of liner systems including SureSeal (foam) and heat induction (foil) liners. Liners can be cut round or with a tri-tab easy-open feature. Can be embossed/debossed with custom message. Offset printing is available in up to four colors.

MEDIUM & DEEP SKIRTED CLOSURES

70-470-9620 S

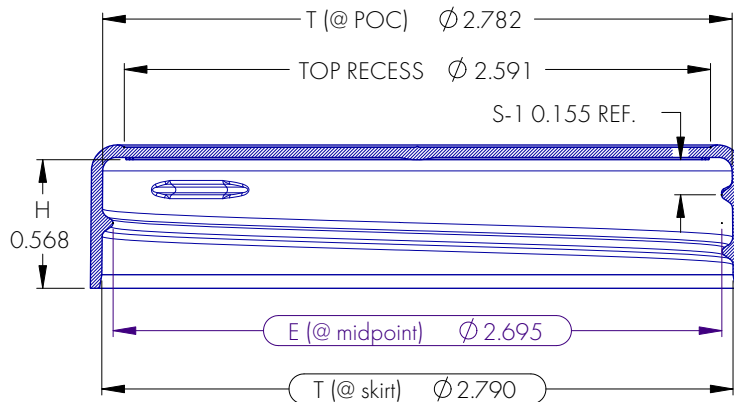
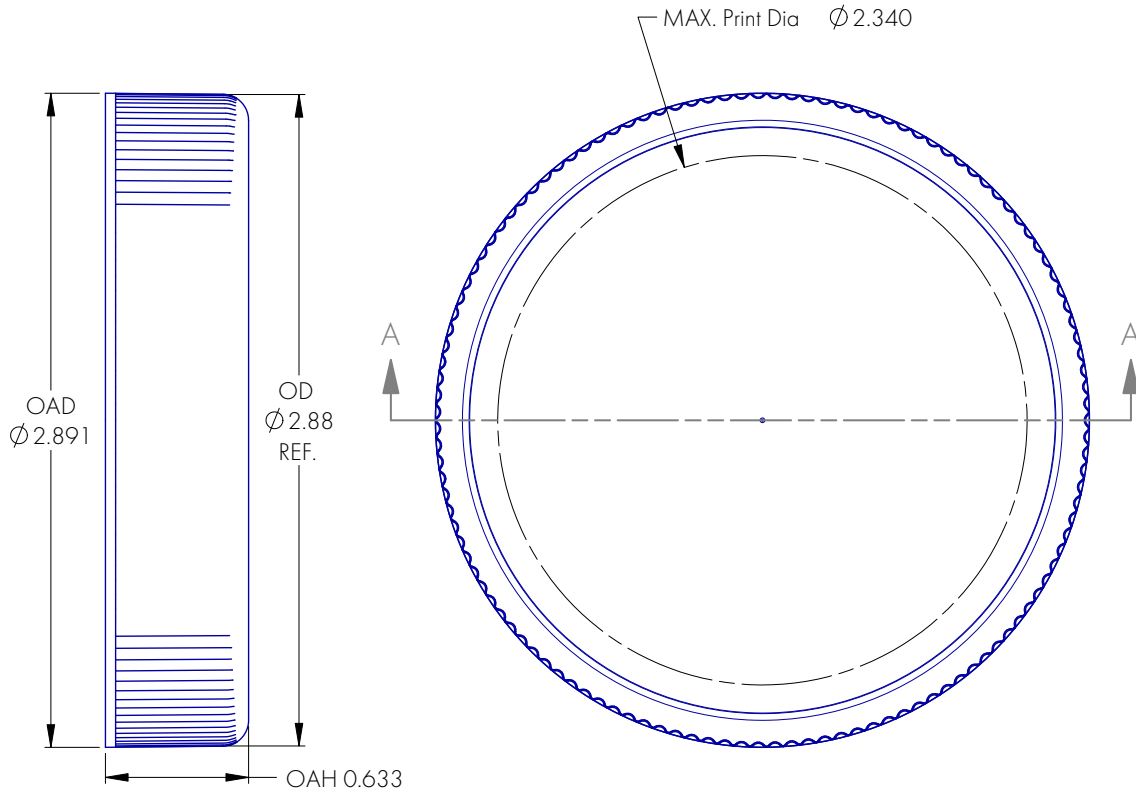

NOTES: (UNLESS OTHERWISE SPECIFIED) 1. ALL DIMENSIONS ARE IN INCHES. 2. SEE CHART FOR DIMENSIONAL TOLERANCE. THIS OR FACSIMILE THEREOF IS THE EXCLUSIVE PROPERTY OF PHOENIX AND MAY NOT BE REPRODUCED WITHOUT THE EXPRESSED WRITTEN CONSENT OF PHOENIX. SOME OR ALL OF THE ITEMS DEPICTED ON THIS DRAWING MAY BE COVERED BY CURRENT PATENTS OR PATENTS APPLIED FOR BY PHOENIX.	5	03.02.21	Updated Int. Height Dimension Ref. Pt.	DN	
	REV	DATE	DESCRIPTION	BY	
	TOLERANCE	PITCH/TPI .250 / 4 TURNS 1-3/16		MAT'L PP	
	.X ±0.1	DRAWN DMN	DATE 11.04.08	SCALE 3 : 2	REV
	.XX ±0.02	070 - 470 - 9620 S			5
.XXX ±0.010					

MEDIUM & DEEP SKIRTED CLOSURES

70-470-9620 S

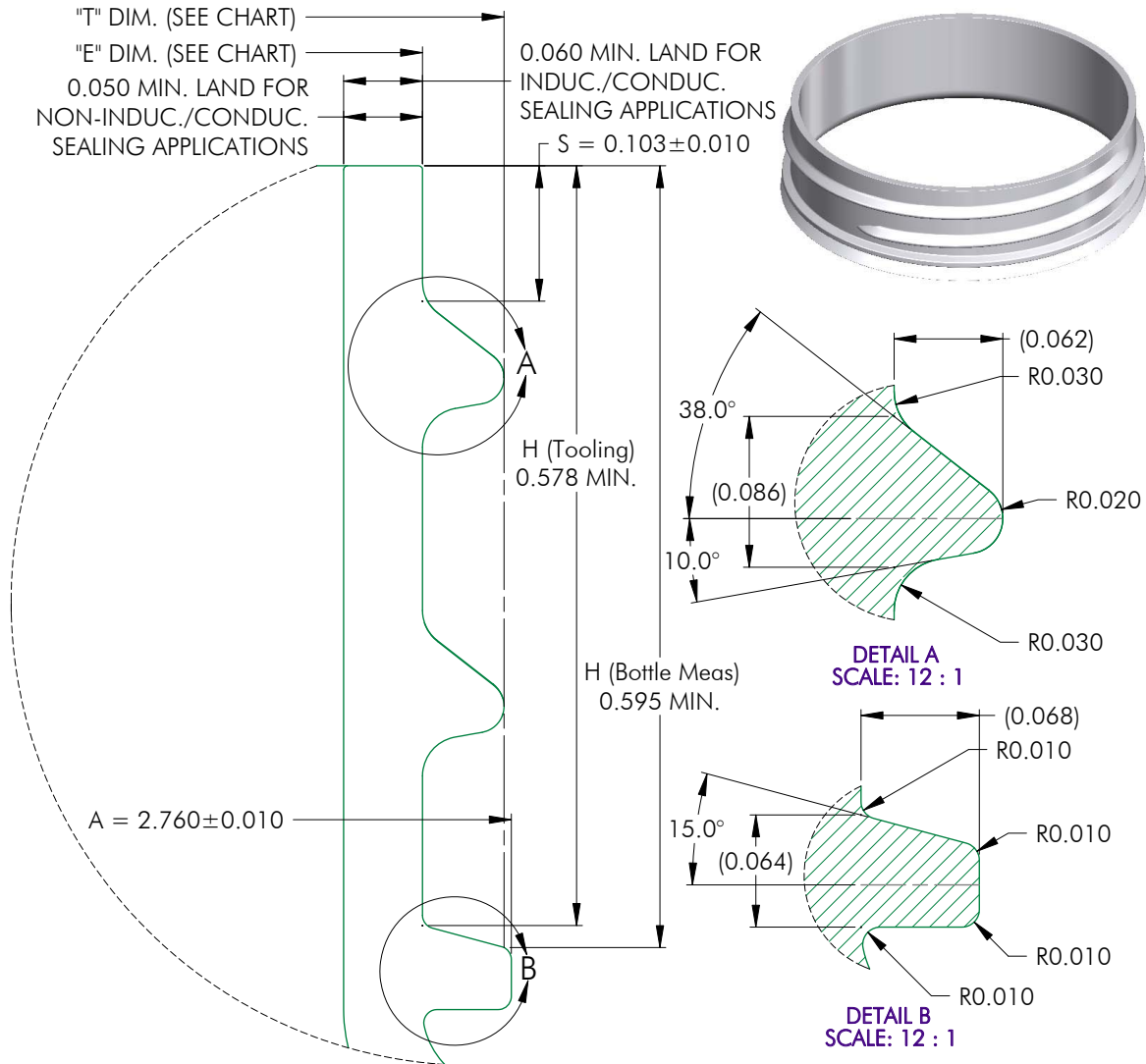

MATERIAL	T (mean)	E (mean)	TOLERANCE
PP / PE	2.750	2.625	± 0.020
PET	2.760	2.635	± 0.010
GLASS	2.750	2.625	± 0.020

NOTES: (UNLESS OTHERWISE SPECIFIED) 1. ALL DIMENSIONS ARE IN INCHES. 2. SEE CHART FOR DIMENSIONAL TOLERANCE.		0	12.06.95	Released	BZ
REV	DATE	DESCRIPTION			BY
TOLERANCE		PITCH/TPI	.250 / 4	TURNS	1-1/4
MATERIAL		SEE CHART			
.X	±0.1	DRAWN	BEZ	DATE	10.09.02
.XX	±0.02	SCALE		9 : 1	REV
.XXX	±0.010	70 - 470 - FINISH			0