

MEDIUM & DEEP SKIRTED CLOSURES

# 70-450-4901 S



## Specifications:

**DIAMETER** 70 mm  
**THREAD PROFILE** 450  
**NECK FINISH** 70-450  
**CLOSURE TOP** Stipple  
**CLOSURE SIDEWALL:** Broad Ribbed  
**MATERIAL** PP

### PACKAGING & FREIGHT INFORMATION

PACK TYPE	PCS/CTN	CTNS/PALT	PCS/PALT	CTN WT*	PALT WT*	FRT CLASS
Stack	800	15	12,000	21 <sup>(1)</sup>	349 <sup>(1)</sup>	125 <sup>(1)</sup>
Stack	800	15	12,000	23 <sup>(2)</sup>	370 <sup>(2)</sup>	125 <sup>(2)</sup>
<b>CARTON DIMENSIONS:</b> 24 x 16 x 15			<b>PALLET DIMENSIONS:</b> 48 x 40 x 50			

(1) Unlined Closures (2) Lined Closures \*Approximate

### MARKETS

Dressings & Sauces, Food, Food Service, Personal Care & Cosmetics, Peanut Butter & Nuts, and Powdered Drinks, Pharmaceuticals, Agricultural and Automotive Products.

### CLOSURE BENEFITS

- Broad-ribbed sides are easier to grip
- Popular for mayonnaise products & dressings, peanut butter & nuts

### OPTIONS

Available in white, standard colors and custom colors. Can be lined with a wide variety of liner systems including SureSeal (foam), pressure sensitive and heat induction (foil) liners. Can be embossed/debossed with custom message. Offset printing is available in up to four colors.

**MEDIUM & DEEP SKIRTED CLOSURES**

# 70-450-4901 S

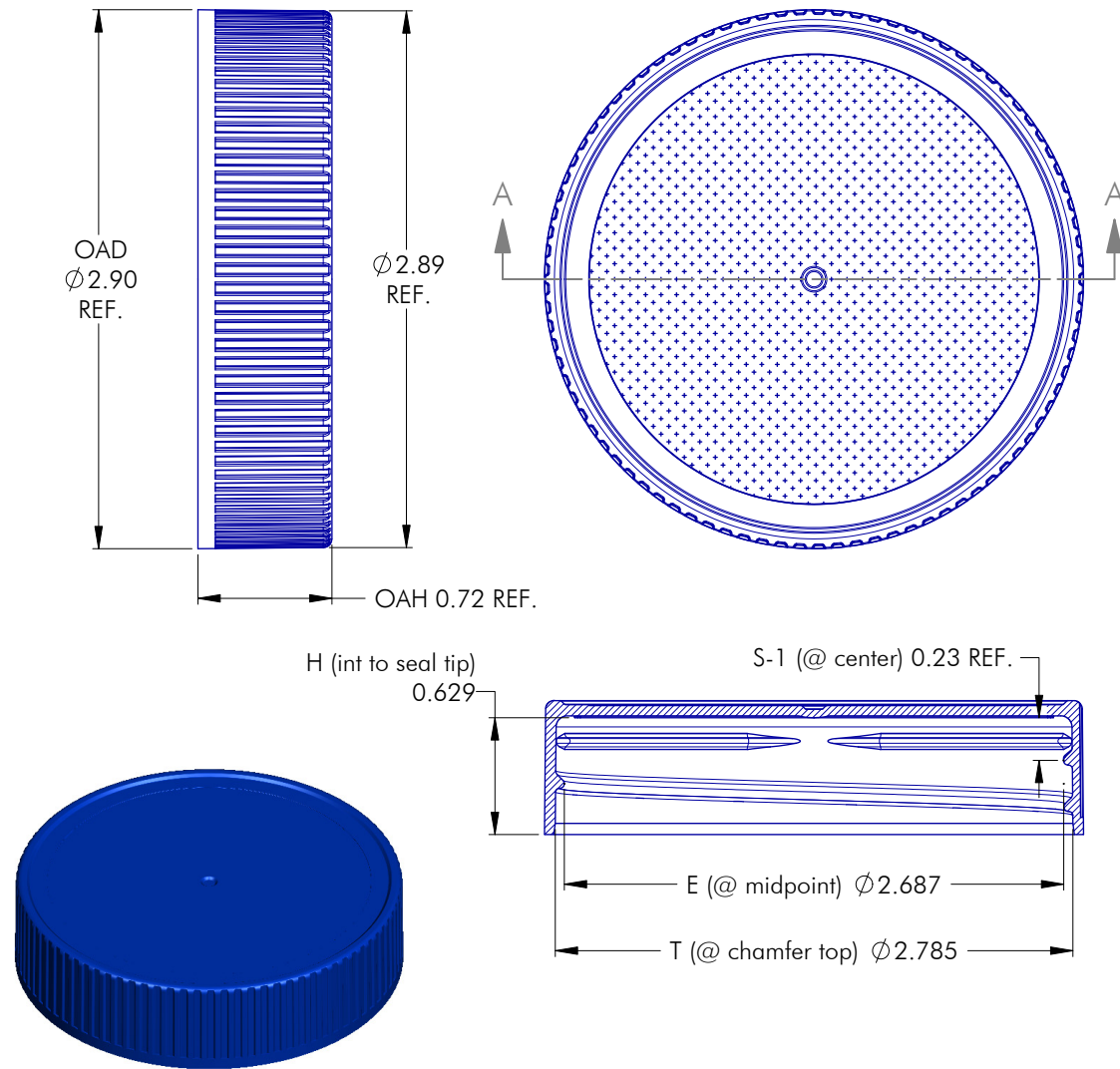

NOTES: (UNLESS OTHERWISE SPECIFIED) 1. ALL DIMENSIONS ARE IN INCHES. 2. SEE CHART FOR DIMENSIONAL TOLERANCE.				1	10.18.06	Updated Dimensions		BZ
REV		DATE		DESCRIPTION			BY	
TOLERANCE		PITCH/TPI		TURN	MAT'L		PP	
.X	±0.1	.250 / 4		1-1/8			REV	
.XX	±0.02	DRAWN		BEZ	DATE	SCALE	1-1/4 : 1	
.XXX	±0.010			70 - 450 - 4901 S			1	

**MEDIUM & DEEP SKIRTED CLOSURES**

# 70-450-4901 S

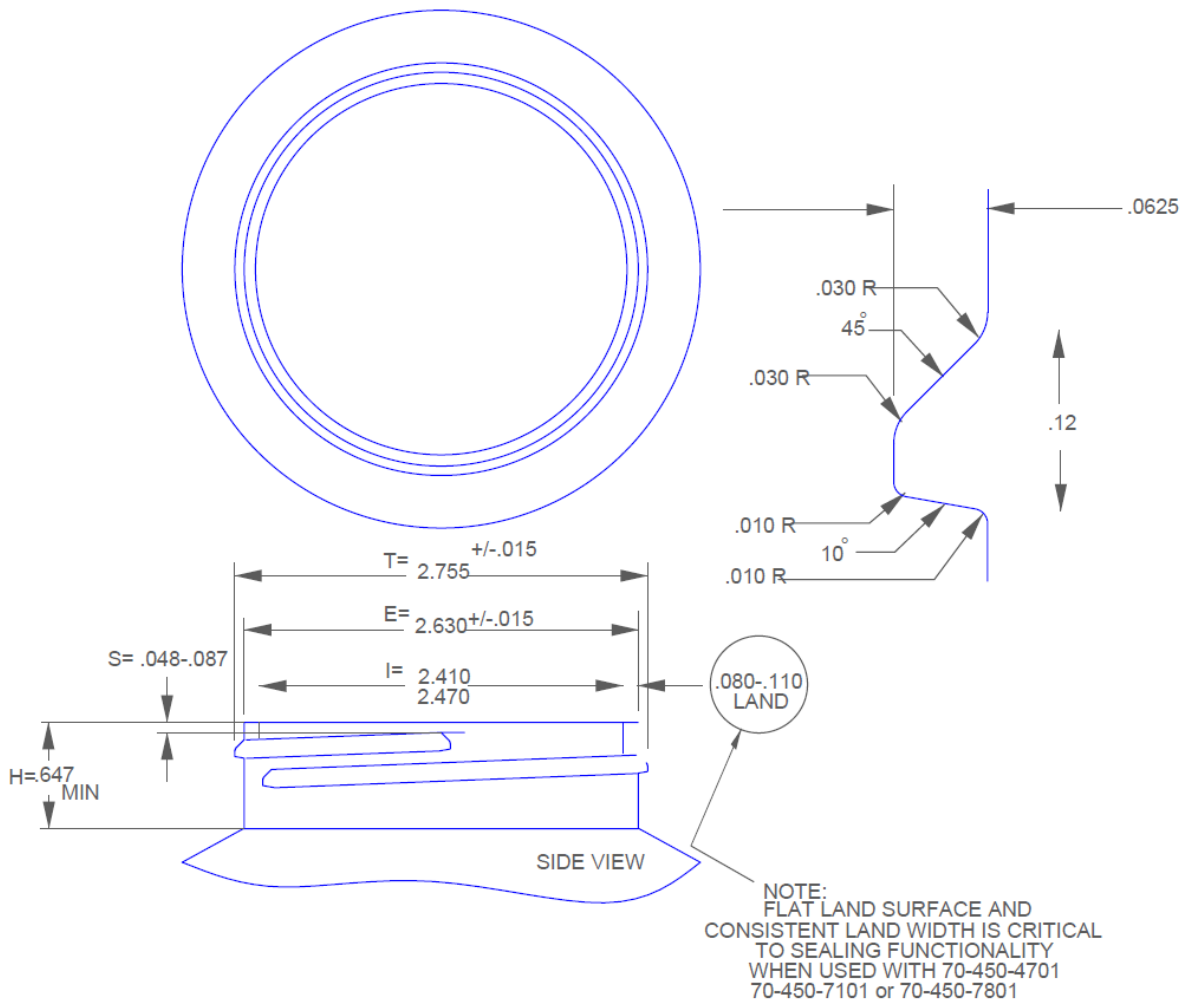

NOTES: (UNLESS OTHERWISE SPECIFIED) 1. ALL DIMENSIONS ARE IN INCHES. 2. SEE CHART FOR DIMENSIONAL TOLERANCE.  THIS OR FACSIMILE THEREOF IS THE EXCLUSIVE PROPERTY OF PHOENIX AND MAY NOT BE REPRODUCED WITHOUT THE EXPRESSED WRITTEN CONSENT OF PHOENIX. SOME OR ALL OF THE ITEMS DEPICTED ON THIS DRAWING MAY BE COVERED BY CURRENT PATENTS OR PATENTS APPLIED FOR BY PHOENIX.	0	07.11.02	Released	BZ				
	REV	DATE	DESCRIPTION	BY				
	TOLERANCE	PITCH/TPI	250 / 4	TURNS	1-1/4	MAT'L	Per Chart	REV
	.X	±0.1	DRAWN	BEZ	DATE	07.11.02	SCALE	10 : 1
	.XX	±0.02	<b>70 - 450 - FINISH</b>			0		
.XXX	±0.010							