

VISTA CHILD-RESISTANT CLOSURES

63-CRC-SMPT A

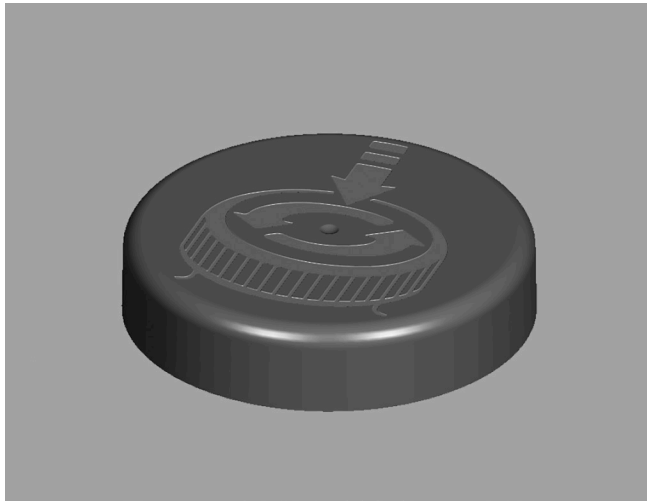

Specifications:

DIAMETER 63 mm
THREAD PROFILE CRC
NECK FINISH 63-CRC
CLOSURE TOP Debossed Pictogram
CLOSURE SIDEWALL Smatte™
MATERIAL PP, PCR PP

PACKAGING & FREIGHT INFORMATION

PACK TYPE	PCS/CTN	CTNS/PALT	PCS/PALT	CTN WT*	PALT WT*	FRT CLASS
Bulk	1,000	15	15,000	32 ⁽¹⁾	480 ⁽¹⁾	100 ⁽¹⁾
Bulk	1,000	15	15,000	32 ⁽²⁾	480 ⁽²⁾	100 ⁽²⁾
CARTON DIMENSIONS: 24 x 16 x 15			PALLET DIMENSIONS: 48 x 40 x 50			

(1) Unlined Closures (2) Lined Closures *Approximate

MARKETS

Vitamins, Nutraceuticals, Pharmaceuticals, Supplements, Agricultural Products, Automotive Products, Household Chemicals, Cosmetics, Industrial Products, Cannabis, and Nutritional Powders

OPTIONS

Available in white, standard, and custom colors. Can be lined with a wide variety of liner systems including SureSeal (foam). Optional 25-30% food-contact safe PCR PP material available.

CLOSURE BENEFITS

- Patented Smatte™ finish for a sleek look
- Offers child-resistance feature
- Vista® 2-piece CRC
- Push-and-turn
- Debossed with pictogram instructions
- Popular for vitamins & nutraceuticals



PHXPKG.COM

P 630 420 4750 **E** greatpkg@phxpkg.com
 975 Meridian Lake Drive • Aurora, IL 60504

VISTA CHILD-RESISTANT CLOSURES

63-CRC-SMPT A

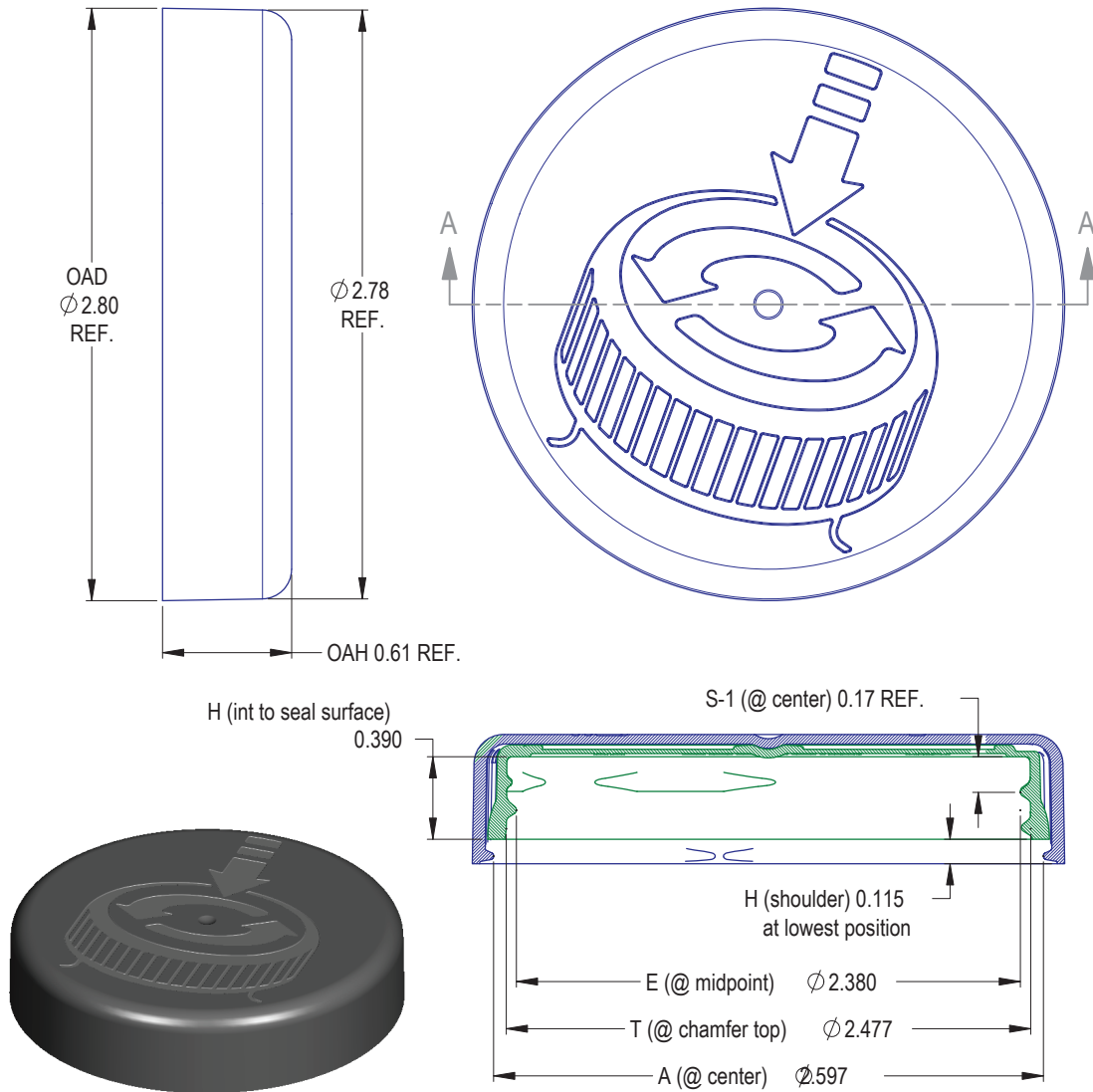

NOTES: (UNLESS OTHERWISE SPECIFIED)				1	11.04.19	Adjust OD of Inner Component Mold	DN
1. ALL DIMENSIONS ARE IN INCHES.				REV	DATE	DESCRIPTION	BY
2. SEE CHART FOR DIMENSIONAL TOLERANCE.							
TOLERANCE		PITCH/TPI	.167 / 6	URNS	356°	MAT'L	PP
.X	±0.1	DRAWN	DMN	DATE	09.02.16	SCALE	3 : 2
.XX	±0.02			63 - CRC - SMPT S		REV	1
.XXX	±0.010						

VISTA CHILD-RESISTANT CLOSURES

63-CRC-SMPT A

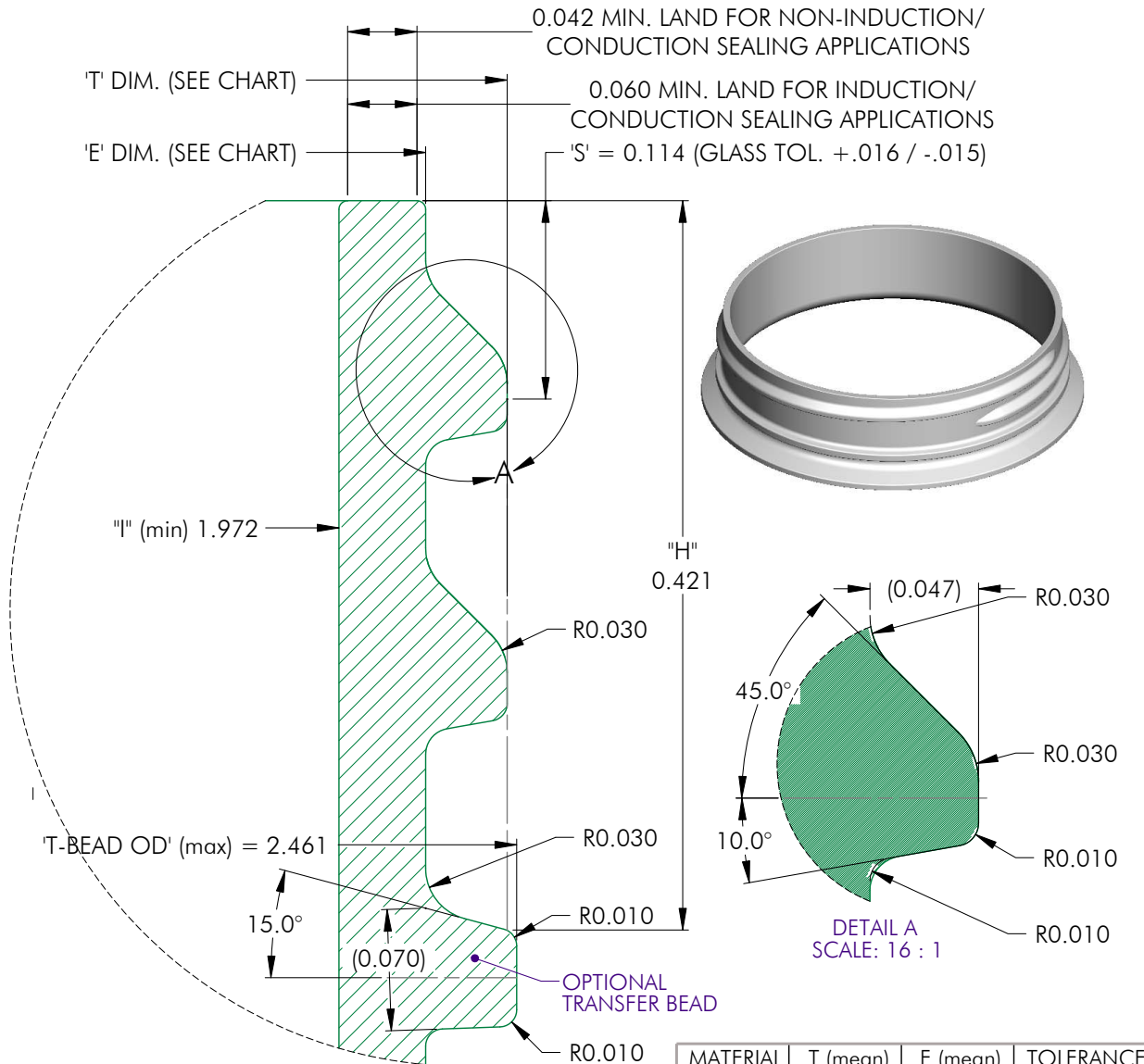

MATERIAL	T (mean)	E (mean)	TOLERANCE
PP / PE	2.4435	2.3495	± 0.0175
PET	2.451	2.357	± 0.010
GLASS	0.0000	0.0000	± 0.0000

<p>NOTES: (UNLESS OTHERWISE SPECIFIED) 1. ALL DIMENSIONS ARE IN INCHES. 2. SEE CHART FOR DIMENSIONAL TOLERANCE.</p> <p>THIS OR FACSIMILE THEREOF IS THE EXCLUSIVE PROPERTY OF PHOENIX AND MAY NOT BE REPRODUCED WITHOUT THE EXPRESSED WRITTEN CONSENT OF PHOENIX. SOME OR ALL OF THE ITEMS DEPICTED ON THIS DRAWING MAY BE COVERED BY CURRENT PATENTS OR PATENTS APPLIED FOR BY PHOENIX.</p>	0	09.08.07	Released	DN					
	REV	DATE	DESCRIPTION	BY					
	TOLERANCE	PITCH/TPI	6 / 0	TURNS	1-1/2	MAT'L	SEE CHART		
	.X	±0.1	DRAWN	DMN	DATE	09.08.07	SCALE	12 : 1	REV

63 - 400 - FINISH