

MEDIUM & DEEP SKIRTED CLOSURES

63-485-9901 S



Specifications:

DIAMETER 63 mm
THREAD PROFILE 485
NECK FINISH 63-485
CLOSURE TOP Stipple
CLOSURE SIDEWALL: Broad Ribbed
MATERIAL PP

PACKAGING & FREIGHT INFORMATION

PACK TYPE	PCS/CTN	CTNS/PALT	PCS/PALT	CTN WT*	PALT WT*	FRT CLASS
Bulk	925	15	13,875	18 ⁽¹⁾	268 ⁽¹⁾	150 ⁽¹⁾
Bulk	925	15	13,975	19 ⁽²⁾	291 ⁽²⁾	125 ⁽²⁾
CARTON DIMENSIONS: 24 x 16 x 15			PALLET DIMENSIONS: 48 x 40 x 50			

(1) Unlined Closures (2) Lined Closures *Approximate

MARKETS

Food, Food Service, Personal Care & Cosmetics, Peanut Butter & Nuts, and Powdered Drinks.

CLOSURE BENEFITS

- Broad-ribbed sides are easier to grip
- Popular for mayonnaise products & dressings, peanut butter & nuts

OPTIONS

Available in white, standard colors and custom colors. Can be lined with a wide variety of liner systems including SureSeal (foam), pressure sensitive and heat induction (foil) liners. Liners can be cut with a pull-tab easy-open feature. Can be embossed/debossed with custom message. Offset printing is available in up to three colors.

MEDIUM & DEEP SKIRTED CLOSURES

63-485-9901 S

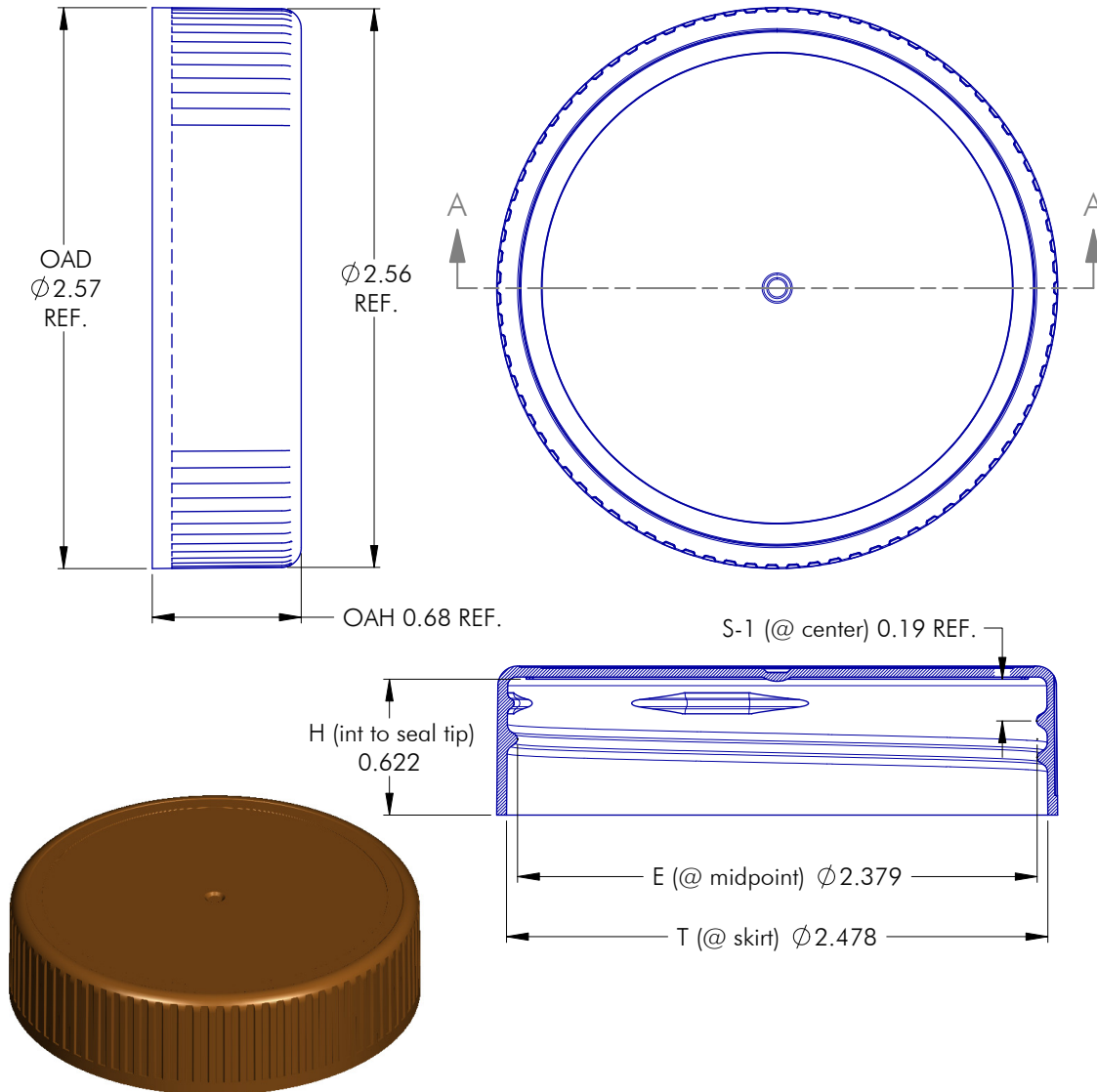

NOTES: (UNLESS OTHERWISE SPECIFIED) 1. ALL DIMENSIONS ARE IN INCHES. 2. SEE CHART FOR DIMENSIONAL TOLERANCE.				1	06.12.08	Modify Exterior Height & Panel Depth	DN	
REV		DATE		DESCRIPTION			BY	
TOLERANCE		PITCH/TPI .167 / 6		TURNS 1-1/4		MAT'L PP		
.X	±0.1	DRAWN DMN	DATE 03.06.08	SCALE 3 : 2	REV			
.XX	±0.02	63 - 485 - 9901 S					1	
.XXX	±0.010							

MEDIUM & DEEP SKIRTED CLOSURES

63-485-9901 S

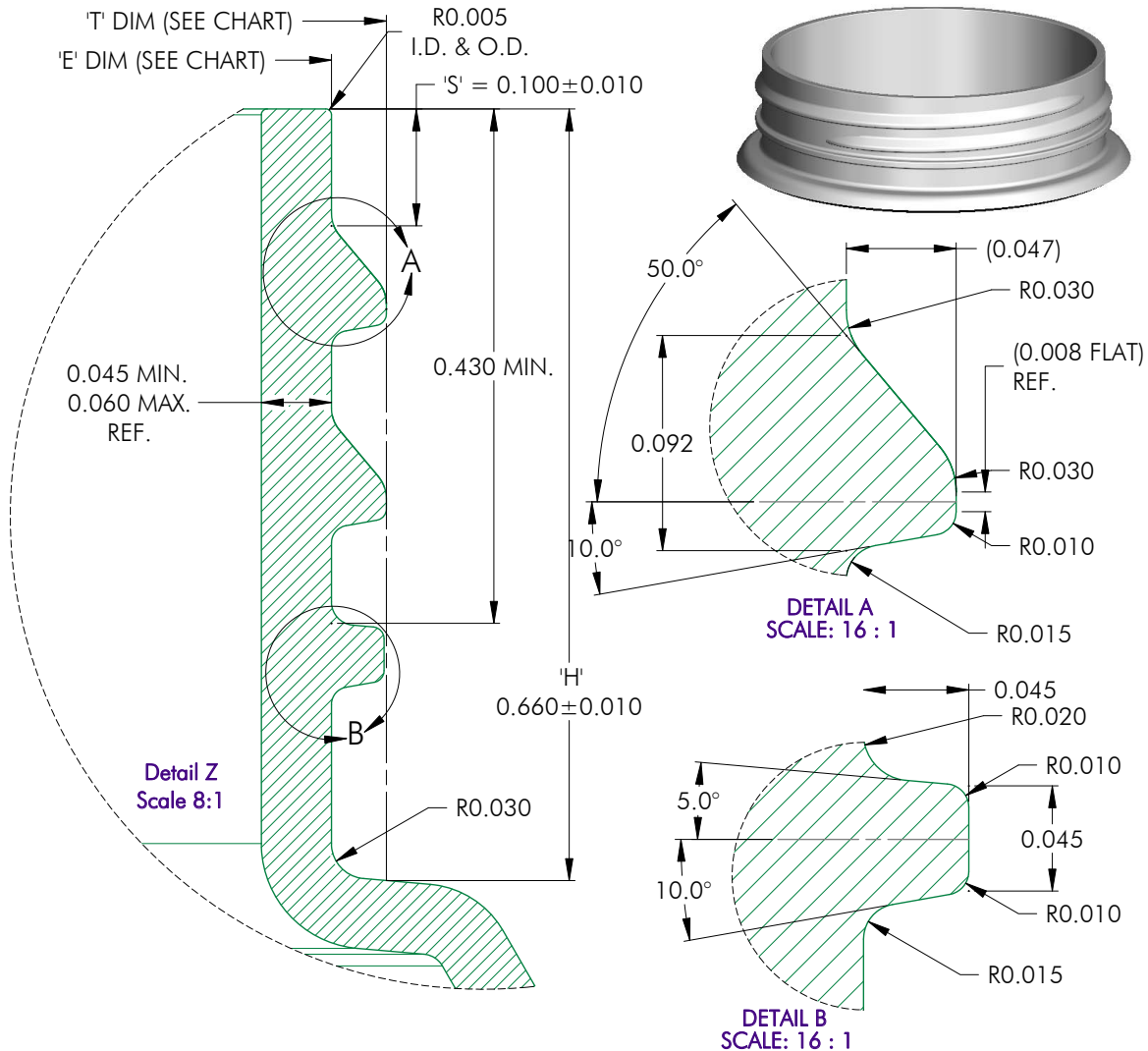

MATERIAL	T (mean)	E (mean)	TOLERANCE
PP / PE	2.442	2.348	± 0.016
PET	2.448	2.354	± 0.010
GLASS	0.0000	0.0000	± 0.0000

NOTES: (UNLESS OTHERWISE SPECIFIED) 1. ALL DIMENSIONS ARE IN INCHES. 2. SEE CHART FOR DIMENSIONAL TOLERANCE. THIS OR FACSIMILE THEREOF IS THE EXCLUSIVE PROPERTY OF PHOENIX AND MAY NOT BE REPRODUCED WITHOUT THE EXPRESSED WRITTEN CONSENT OF PHOENIX. SOME OR ALL OF THE ITEMS DEPICTED ON THIS DRAWING MAY BE COVERED BY CURRENT PATENTS OR PATENTS APPLIED FOR BY PHOENIX.	0	07.29.10	Released	DN	
	REV	DATE	DESCRIPTION	BY	
	TOLERANCE	PITCH/TPI .167 / 6		TURNS 1-3/16	MAT'L PER CHART
	.X ±0.1	DRAWN DMN	DATE 07.29.10	SCALE 8 : 1	REV
	.XX ±0.02	63 - 485 - FINISH			0