

MESA DISPENSING CLOSURES

38-DIS-1R38 S



Specifications:

DIAMETER 38 mm
THREAD PROFILE 400
CLOSURE TYPE Dispensing
NECK FINISH 38-400
CLOSURE TOP Flip-top
CLOSURE SIDEWALL Ribbed
MATERIAL PP

PACKAGING & FREIGHT INFORMATION

PACK TYPE	PCS/CTN	CTNS/PALT	PCS/PALT	CTN WT*	PALT WT*	FRT CLASS
Bulk	2,250	15	33,750	30.6 ⁽¹⁾	459 ⁽¹⁾	100 ⁽¹⁾
Bulk	2,250	15	33,750	TBD ⁽²⁾	TBD ⁽²⁾	TBD ⁽²⁾
CARTON DIMENSIONS: 24 x 16 x 15			PALLET DIMENSIONS: 48 x 40 x 50			

(1) Unlined Closures (2) Lined Closures *Approximate

MARKETS

Dressings & Sauces, Honey, Jams and Jellies, Condiments, Lotions, Cleansers, Cleaning Products.

OPTIONS

Available in white, standard colors and custom colors. Can be lined with a wide variety of liner systems.

CLOSURE BENEFITS

- Easy dispensing & clean flow
- MESA Flip-top dispensing closure
- 0.375" orifice
- Audible "click" conveys security
- Single-wall design

MESA DISPENSING CLOSURES

38-DIS-1R38 S

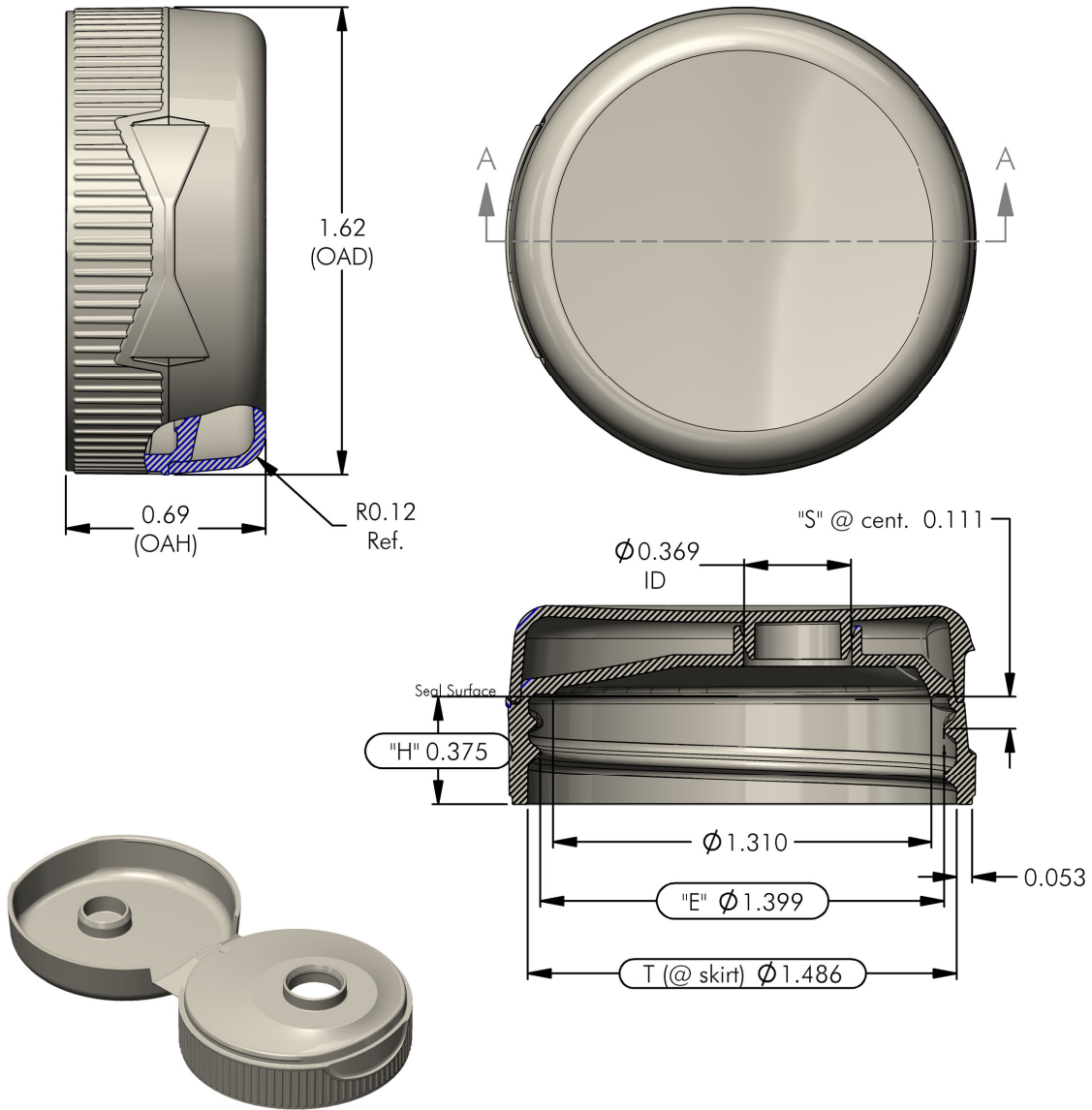

5.095

NOTES: (UNLESS OTHERWISE SPECIFIED)		- 00.00.00 -		-	
1. ALL DIMENSIONS ARE IN INCHES.		REV	DATE	DESCRIPTION	BY
2. SEE CHART FOR DIMENSIONAL TOLERANCE.		TOLERANCE	PITCH/TPI .167 / 6	TURNS 1-1/8	MAT'L PP
THIS OR FACSIMILE THEREOF IS THE EXCLUSIVE PROPERTY OF PHOENIX AND MAY NOT BE REPRODUCED WITHOUT THE EXPRESSED WRITTEN CONSENT OF PHOENIX. SOME OR ALL OF THE ITEMS DEPICTED ON THIS DRAWING MAY BE COVERED BY CURRENT PATENTS OR PATENTS APPLIED FOR BY PHOENIX.		.X ±0.1	DRAWN TCS	DATE 11.02.20	SCALE 2 : 1
		.XX ±0.02	038 - DIS - 1R38 S		
		.XXX ±0.010			

MESA DISPENSING CLOSURES

38-DIS-1R38 S

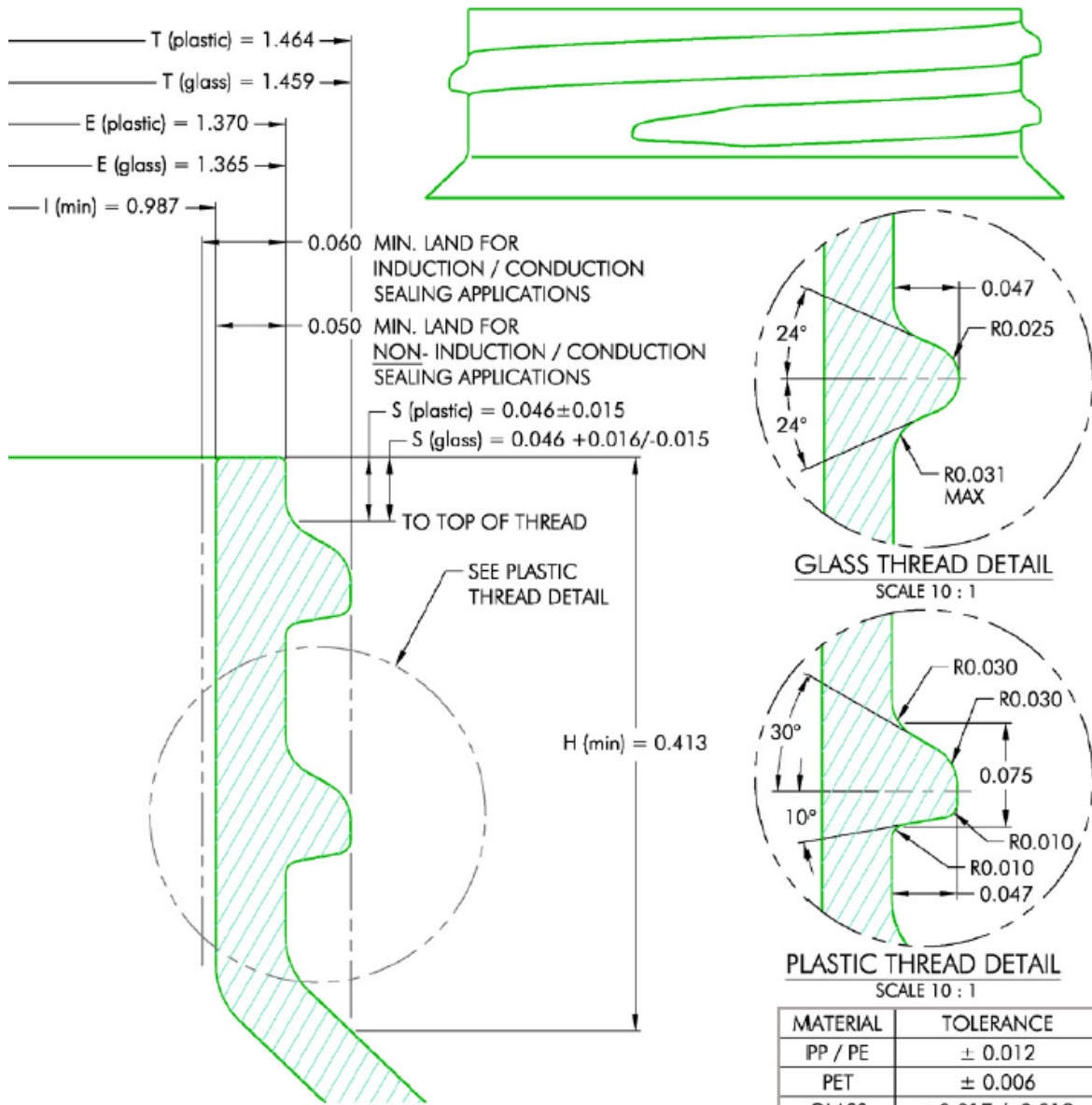

NOTES: (UNLESS OTHERWISE SPECIFIED)

- ALL DIMENSIONS ARE IN INCHES.
- SEE CHART FOR DIMENSIONAL TOLERANCE.

THIS OR FACSIMILE THEREOF IS THE EXCLUSIVE PROPERTY OF PHOENIX AND MAY NOT BE REPRODUCED WITHOUT THE EXPRESSED WRITTEN CONSENT OF PHOENIX. SOME OR ALL OF THE ITEMS DEPICTED ON THIS DRAWING MAY BE COVERED BY CURRENT PATENTS OR PATENTS APPLIED FOR BY PHOENIX.

BF	05.21.18	Released	DN
REV	DATE	DESCRIPTION	BY
TOLERANCE	PITCH/TPI	1.67 / 6	TURNS 1-1/4
.X	± 0.1	DRAWN BEZ	DATE 08.31.93
.XX	± 0.02	SCALE	10 : 1
.XXX	± 0.010	38 - 400 - FINISH	0