

MEDIUM & DEEP SKIRTED CLOSURES

38-8TP-62 S



Specifications:

DIAMETER 38 mm
THREAD PROFILE 8TP
NECK FINISH 38-8TP
CLOSURE TOP Stipple
CLOSURE SIDEWALL: Fine Ribbed
MATERIAL PP, PCR PP

PACKAGING & FREIGHT INFORMATION

PACK TYPE	PCS/CTN	CTNS/PALT	PCS/PALT	CTN WT*	PALT WT*	FRT CLASS
Bulk	3,500	15	52,500	27 ⁽¹⁾	408 ⁽¹⁾	100 ⁽¹⁾
Bulk	3,500	15	52,500	30 ⁽²⁾	452 ⁽²⁾	100 ⁽²⁾
CARTON DIMENSIONS: 24 x 16 x 15			PALLET DIMENSIONS: 48 x 40 x 50			

(1) Unlined Closures (2) Lined Closures *Approximate

CLOSURE BENEFITS

- Stocked in white (colors available)
- Fine-ribbed sides are easier to grip

MARKETS

Dressings & Sauces, Food, Food Service, and Food Oil.

OPTIONS

Available in white, several standard colors and custom colors.

Can be lined with a wide variety of liner systems.

Liners can be cut with a tri-tab easy-open feature.

Optional 25–30% food-contact PCR PP material available

MEDIUM & DEEP SKIRTED CLOSURES

38-8TP-62 S

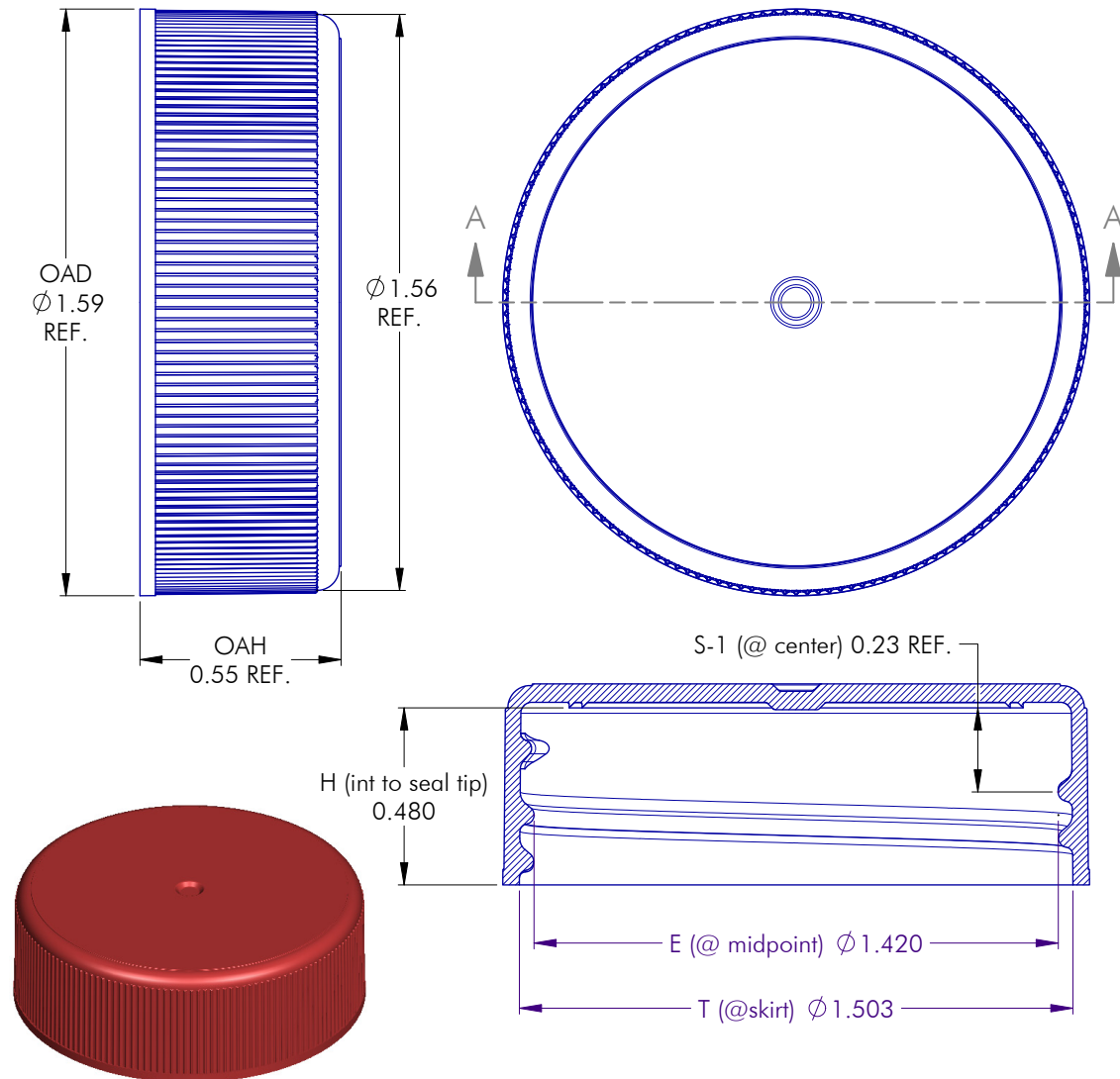

NOTES: (UNLESS OTHERWISE SPECIFIED) 1. ALL DIMENSIONS ARE IN INCHES. 2. SEE CHART FOR DIMENSIONAL TOLERANCE.				7	03.13.06	Modify Interior Diameter Dimensions	BZ
REV	DATE	DESCRIPTION				BY	
TOLERANCE		PITCH/TPI	.125 / 8	TURNS	1-1/8	MAT'L	PP
.X	±0.1	DRAWN	BEZ	DATE	10.31.05	SCALE	5 : 2
.XX	±0.02	38 - 8TP - 62 S				REV	7
.XXX	±0.010						

MEDIUM & DEEP SKIRTED CLOSURES

38-8TP-62 S

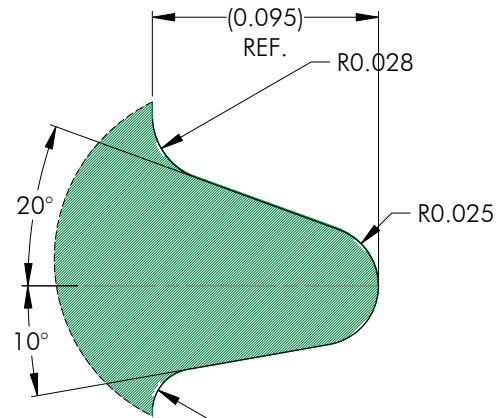
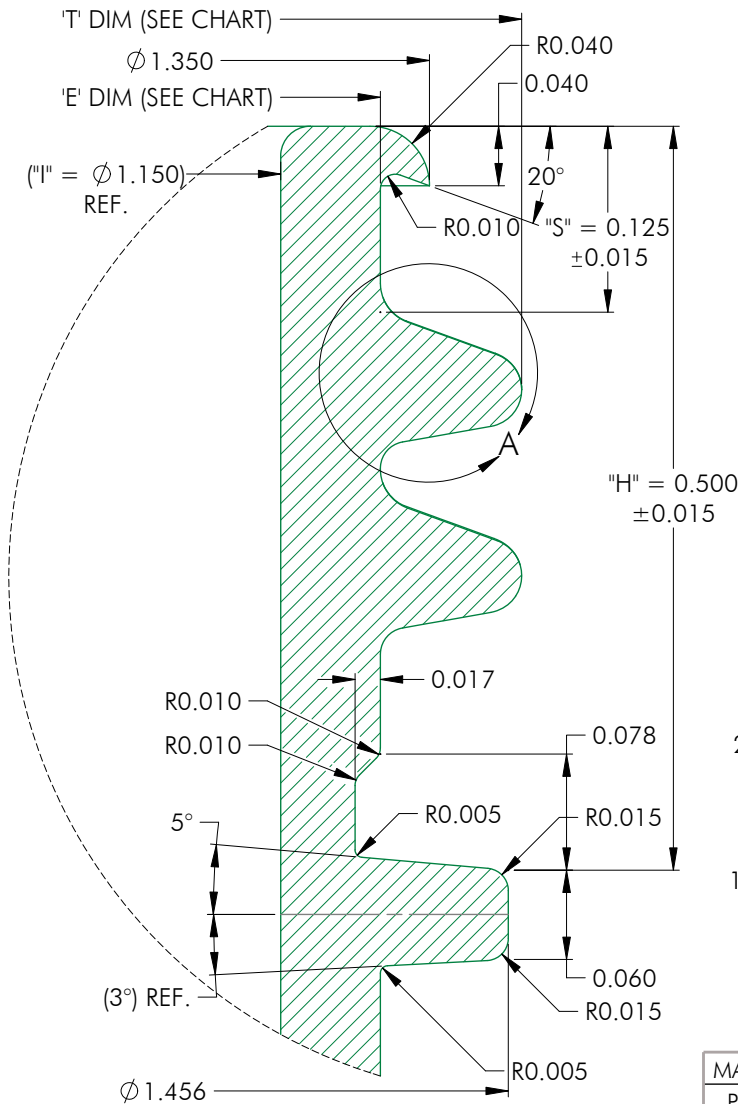

DETAIL A
SCALE: 16 : 1

MATERIAL	T (mean)	E (mean)	TOLERANCE
PP / PE	1.474	1.284	± 0.010
PET	1.476	1.286	± 0.008
GLASS	0.0000	0.0000	± 0.0000

NOTES: (UNLESS OTHERWISE SPECIFIED) 1. ALL DIMENSIONS ARE IN INCHES. 2. SEE CHART FOR DIMENSIONAL TOLERANCE.		0	04.04.06	Released	BZ
REV	DATE	DESCRIPTION		BY	
TOLERANCE	PITCH/TPI	.125 / 8	TURNS	1-1/2	MAT'L PER CHART
.X ±0.1	DRAWN	BEZ	DATE	04.04.06	SCALE 10 : 1
.XX ±0.02	38 - 8TP - FINISH				REV
.XXX ±0.010					0