

MEDIUM & DEEP SKIRTED CLOSURES

38-6TP-H1 S



Specifications:

DIAMETER 38 mm
THREAD PROFILE 6TP
NECK FINISH 38-6TP
CLOSURE TOP Stipple
CLOSURE SIDEWALL: Fine Ribbed
MATERIAL PP

PACKAGING & FREIGHT INFORMATION

PACK TYPE	PCS/CTN	CTNS/PALT	PCS/PALT	CTN WT*	PALT WT*	FRT CLASS
Bulk	2,250	15	33,750	23 ⁽¹⁾	340 ⁽¹⁾	125 ⁽¹⁾
Bulk	2,250	15	33,750	25 ⁽²⁾	368 ⁽²⁾	125 ⁽²⁾
CARTON DIMENSIONS: 24 x 16 x 15			PALLET DIMENSIONS: 48 x 40 x 50			

(1) Unlined Closures (2) Lined Closures *Approximate

MARKETS

Dressings & Sauces, Food, Food Service, and Food Oil

OPTIONS

Available in white, several standard colors and custom colors. Can be lined with a wide variety of liner systems. Liners can be cut with a tri-tab easy-open feature.

CLOSURE BENEFITS

- Stocked in white (colors available)
- Fine-ribbed sides are easier to grip

MEDIUM & DEEP SKIRTED CLOSURES

38-6TP-H1 S

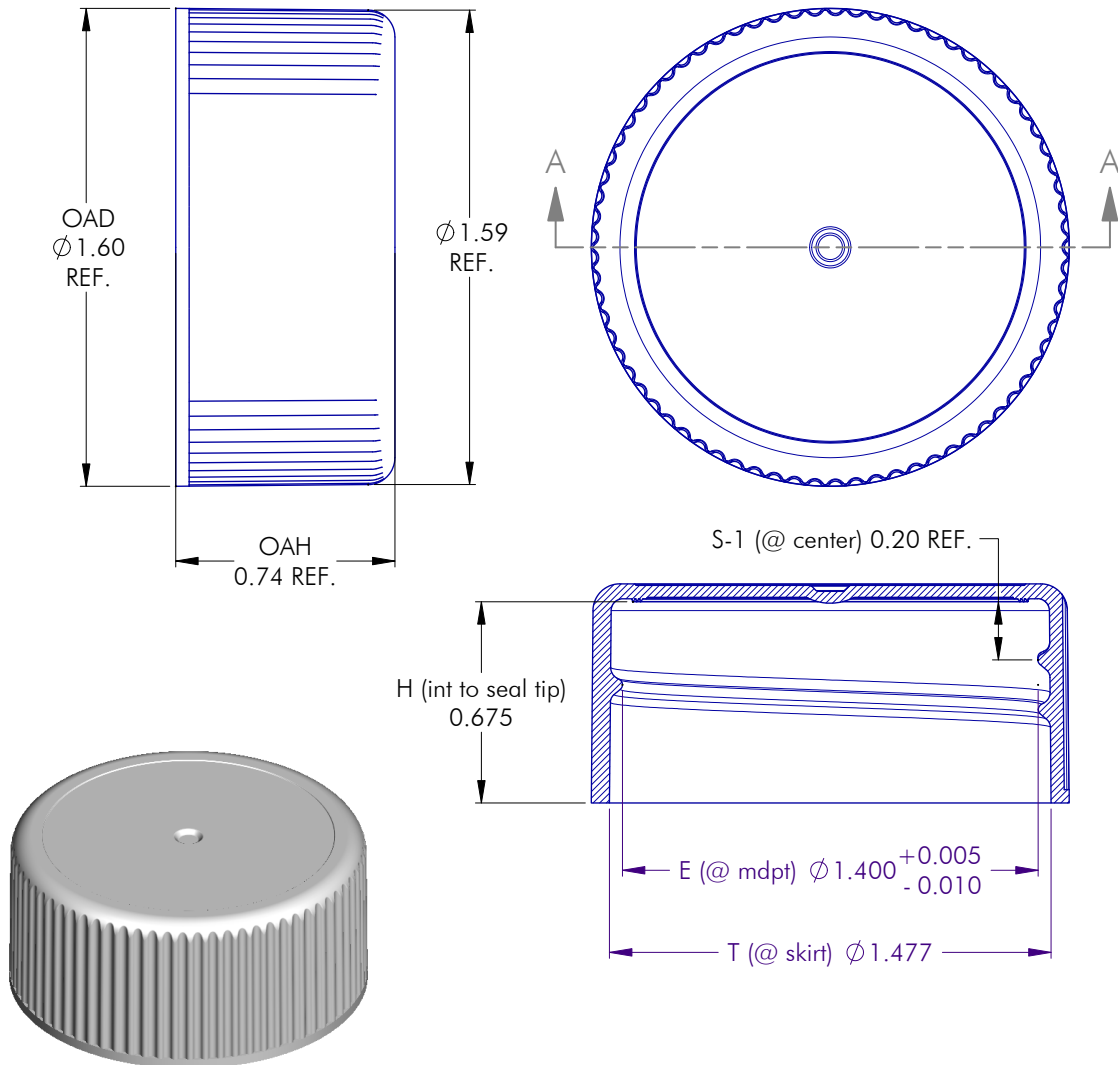

NOTES: (UNLESS OTHERWISE SPECIFIED) 1. ALL DIMENSIONS ARE IN INCHES. 2. SEE CHART FOR DIMENSIONAL TOLERANCE.				8	08.28.14	Modify Seal Ring Profile	DN
REV	DATE	DESCRIPTION				BY	
TOLERANCE		PITCH/TPI .167 / 6	TURNS 1	MAT'L PP			
.X	± 0.1	DRAWN DMN	DATE 08.02.07	SCALE 2 : 1	REV		
.XX	± 0.02	38 - 6TP - H1 S				8	
.XXX	± 0.010						

MEDIUM & DEEP SKIRTED CLOSURES

38-6TP-H1 S

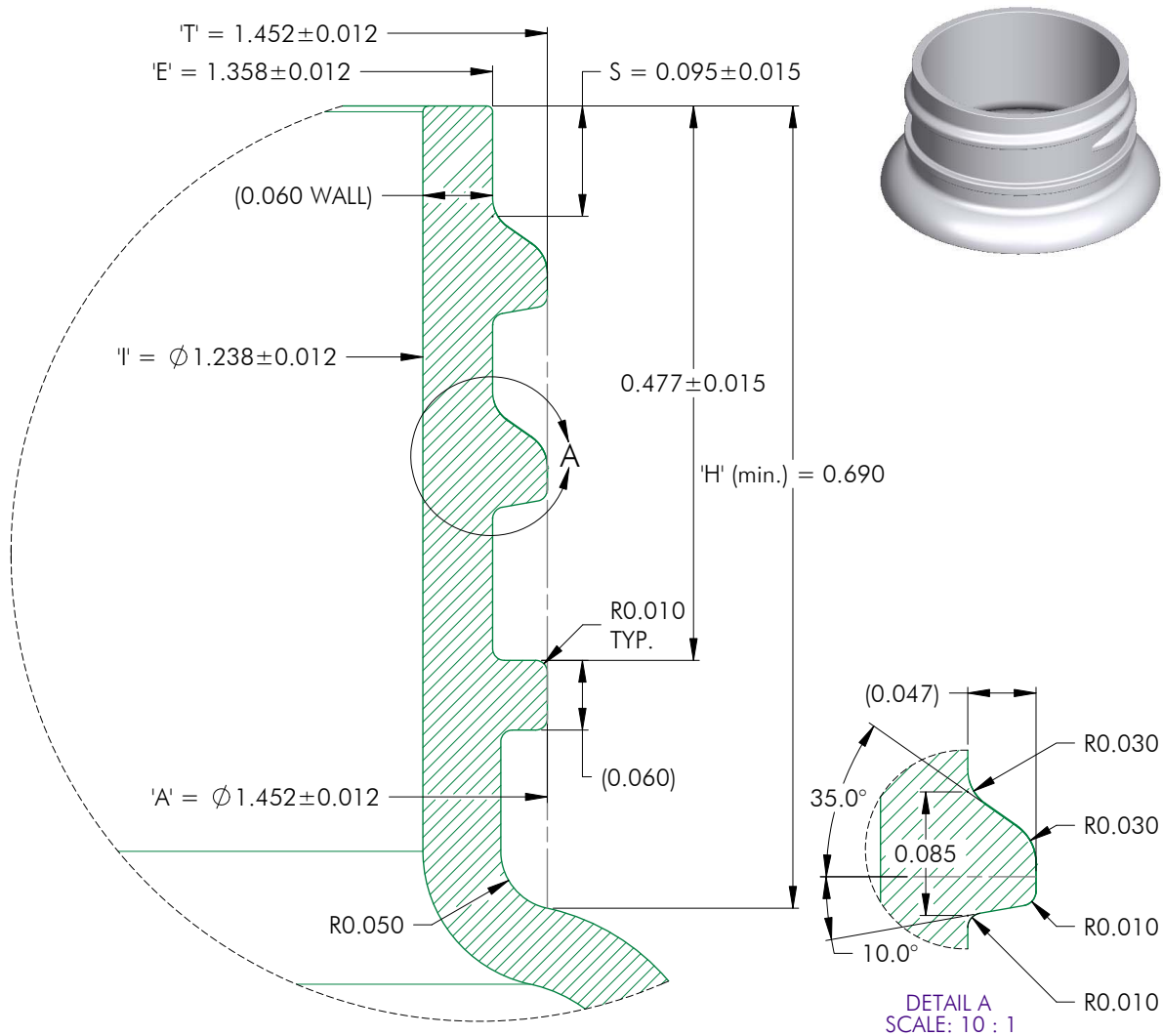

NOTES: (UNLESS OTHERWISE SPECIFIED)		0	06.03.08	Released	DN
1. ALL DIMENSIONS ARE IN INCHES.		REV	DATE	DESCRIPTION	BY
2. SEE CHART FOR DIMENSIONAL TOLERANCE.		TOLERANCE	PITCH/TPI	.167 / 6	TURNS 1
THIS OR FACSIMILE THEREOF IS THE EXCLUSIVE PROPERTY OF PHOENIX AND MAY NOT BE REPRODUCED WITHOUT THE EXPRESSED WRITTEN CONSENT OF PHOENIX. SOME OR ALL OF THE ITEMS DEPICTED ON THIS DRAWING MAY BE COVERED BY CURRENT PATENTS OR PATENTS APPLIED FOR BY PHOENIX.		.X	±0.1	DRAWN DMN	DATE 06.03.08
		.XX	±0.02	SCALE 8 : 1	REV
		.XXX	±0.010	38 - 6TP - H1 FINISH	
					0