

MESA DISPENSING CLOSURES

33-DIS-1R50 S

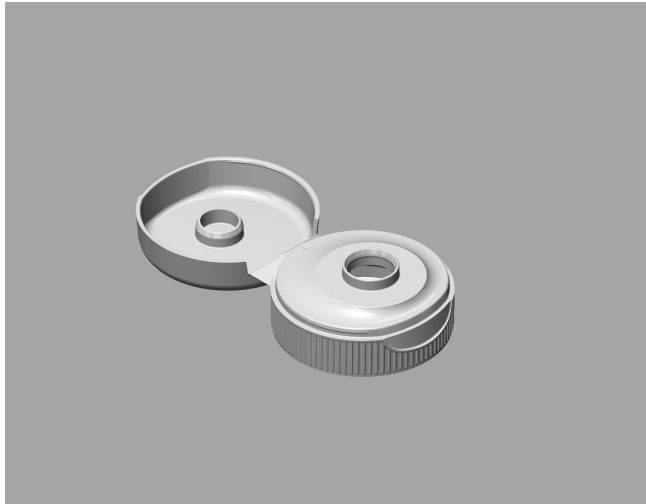

Specifications:

DIAMETER 33 mm
THREAD PROFILE 400
CLOSURE TYPE Dispensing
NECK FINISH 33-400
CLOSURE TOP Flip-top
CLOSURE SIDEWALL Ribbed
MATERIAL PP

PACKAGING & FREIGHT INFORMATION

PACK TYPE	PCS/CTN	CTNS/PALT	PCS/PALT	CTN WT*	PALT WT*	FRT CLASS
Bulk	2,500	15	37,500	28.6 ⁽¹⁾	430 ⁽¹⁾	125 ⁽¹⁾
Bulk	2,500	15	37,500	29.7 ⁽²⁾	446 ⁽²⁾	100 ⁽²⁾
CARTON DIMENSIONS: 24 x 16 x 15			PALLET DIMENSIONS: 48 x 40 x 50			

(1) Unlined Closures (2) Lined Closures *Approximate

MARKETS

Dressings & Sauces, Honey, Jams and Jellies, Condiments, Lotions, Cleansers, Cleaning Products.

OPTIONS

Available in white, standard colors and custom colors. Can be lined with a wide variety of liner systems.

CLOSURE BENEFITS

- Easy dispensing & clean flow
- MESA Flip-top dispensing closure
- 0.50" orifice
- Audible "click" conveys security
- Single-wall design

MESA DISPENSING CLOSURES

33-DIS-1R50 S

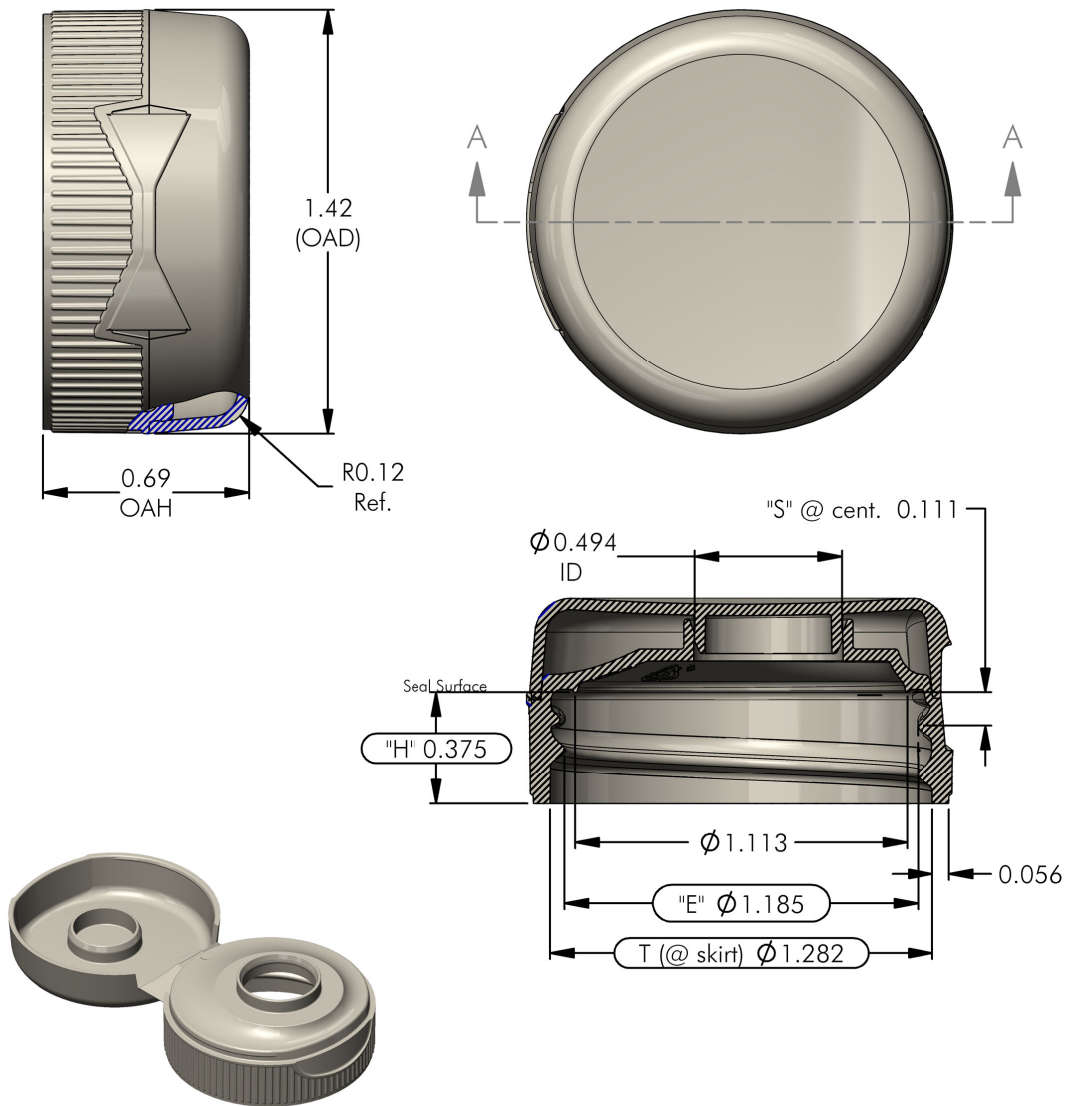

4.236

NOTES: (UNLESS OTHERWISE SPECIFIED)		-	00.00.00	-	-
1. ALL DIMENSIONS ARE IN INCHES.		REV	DATE	DESCRIPTION	BY
2. SEE CHART FOR DIMENSIONAL TOLERANCE.		TOLERANCE	PITCH/TPI	.167 / 6	TURNS 1-1/8
THIS OR FACSIMILE THEREOF IS THE EXCLUSIVE PROPERTY OF PHOENIX AND MAY NOT BE REPRODUCED WITHOUT THE EXPRESSED WRITTEN CONSENT OF PHOENIX. SOME OR ALL OF THE ITEMS DEPICTED ON THIS DRAWING MAY BE COVERED BY CURRENT PATENTS OR PATENTS APPLIED FOR BY PHOENIX.		.X	±0.1	DRAWN TCS	DATE 11.02.20
		.XX	±0.02	SCALE 2 : 1	REV
		.XXX	±0.010	033 - DIS - 1R50 S 0	

MESA DISPENSING CLOSURES

33-DIS-1R50 S

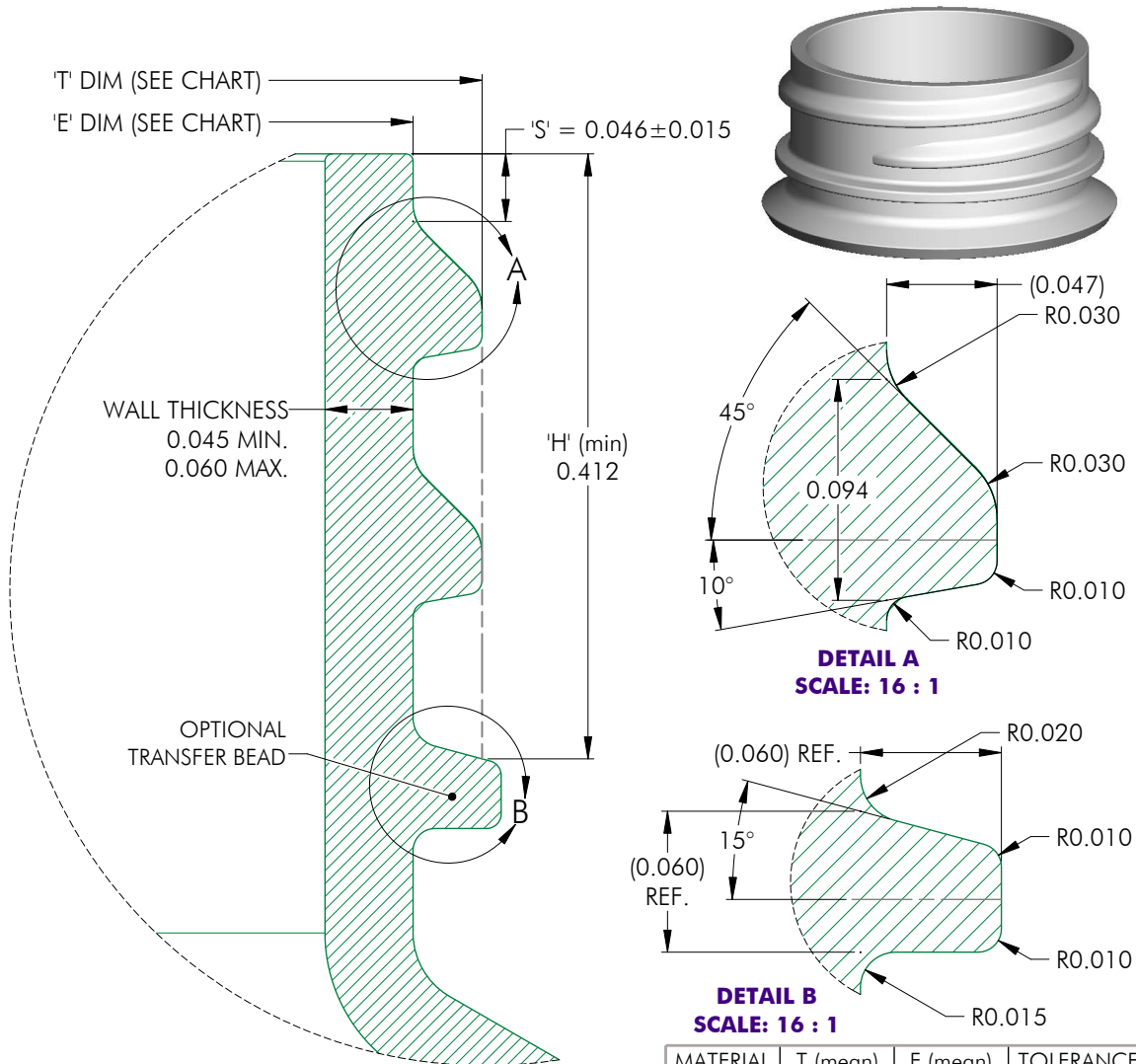

MATERIAL	T (mean)	E (mean)	TOLERANCE
PP / PE	1.253	1.159	± 0.012
PET	1.257	1.163	± 0.008
GLASS	0.0000	0.0000	± 0.0000

NOTES: (UNLESS OTHERWISE SPECIFIED)				1	03.13.17	Update wall thickness to reflect Market	DN						
1. ALL DIMENSIONS ARE IN INCHES.				REV	DATE	DESCRIPTION	BY						
2. SEE CHART FOR DIMENSIONAL TOLERANCE.													
THIS OR FACSIMILE THEREOF IS THE EXCLUSIVE PROPERTY OF PHOENIX AND MAY NOT BE REPRODUCED WITHOUT THE EXPRESSED WRITTEN CONSENT OF PHOENIX. SOME OR ALL OF THE ITEMS DEPICTED ON THIS DRAWING MAY BE COVERED BY CURRENT PATENTS OR PATENTS APPLIED FOR BY PHOENIX.				TOLERANCE	PITCH/TP/	1.67 / 6	TURNS	1-1/8	MAT'L	PER CHART			
				.X	±0.1	DRAWN	DMN	DATE	03.13.17	SCALE	10 : 1	REV	
				.XX	±0.02	33 - 400 - FINISH							
				.XXX	±0.010								