

MESA DISPENSING CLOSURES

# 33-DIS-1 R25 S



## Specifications:

- DIAMETER** 33 mm
- THREAD PROFILE** 400
- CLOSURE TYPE** Dispensing
- NECK FINISH** 33-400
- CLOSURE TOP** Flip-top
- CLOSURE SIDEWALL** Ribbed
- MATERIAL** PP

### PACKAGING & FREIGHT INFORMATION

PACK TYPE	PCS/CTN	CTNS/PALT	PCS/PALT	CTN WT*	PALT WT*	FRT CLASS
Bulk	2,500	15	37,500	28.6 <sup>(1)</sup>	430 <sup>(1)</sup>	125 <sup>(1)</sup>
Bulk	2,500	15	37,500	29.7 <sup>(2)</sup>	446 <sup>(2)</sup>	100 <sup>(2)</sup>
<b>CARTON DIMENSIONS: 24 x 16 x 15</b>			<b>PALLET DIMENSIONS: 48 x 40 x 50</b>			

(1) Unlined Closures (2) Lined Closures \*Approximate

### MARKETS

Dressings & Sauces, Honey, Jams and Jellies, Condiments, Lotions, Cleansers, Cleaning Products.

### OPTIONS

Available in white, standard colors and custom colors. Can be lined with a wide variety of liner systems.

### CLOSURE BENEFITS

- Easy dispensing & clean flow
- Flip-top dispensing closure
- 0.25" orifice
- Audible "click" conveys security
- Single-wall design
- MESA dispensing closure

MESA DISPENSING CLOSURES

# 33-DIS-1R25 S

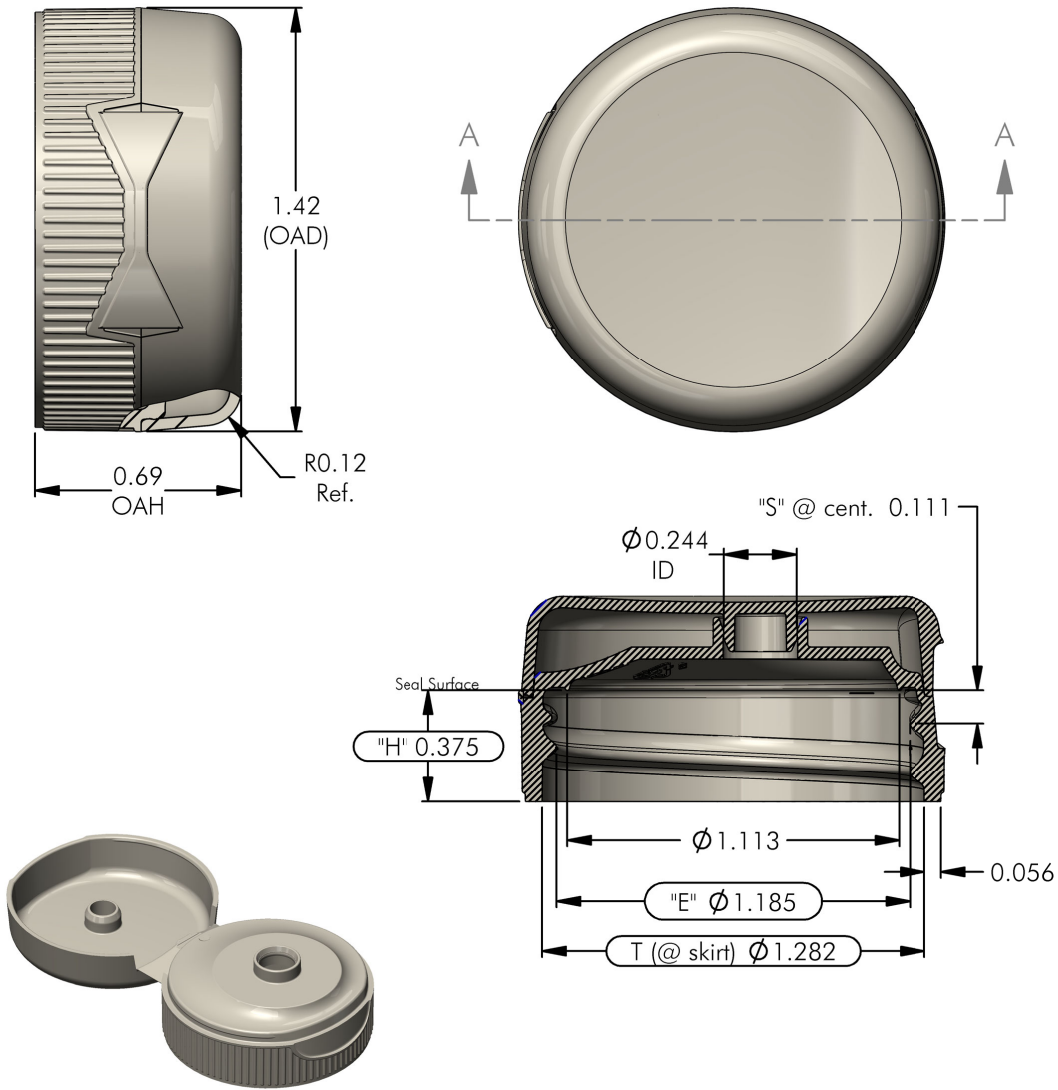

4.236

NOTES: (UNLESS OTHERWISE SPECIFIED)		-	00.00.00	-	-
1. ALL DIMENSIONS ARE IN INCHES.		REV	DATE	DESCRIPTION	BY
2. SEE CHART FOR DIMENSIONAL TOLERANCE.		TOLERANCE	PITCH/TPI	.167 / 6	TURNS
THIS OR FACSIMILE THEREOF IS THE EXCLUSIVE PROPERTY OF PHOENIX AND MAY NOT BE REPRODUCED WITHOUT THE EXPRESSED WRITTEN CONSENT OF PHOENIX. SOME OR ALL OF THE ITEMS DEPICTED ON THIS DRAWING MAY BE COVERED BY CURRENT PATENTS OR PATENTS APPLIED FOR BY PHOENIX.		.X	±0.1	DRAWN	TCS
		.XX	±0.02	DATE	11.02.20
		.XXX	±0.010	SCALE	2 : 1
		<b>033 - DIS - 1R25 S</b>			REV
					0

MESA DISPENSING CLOSURES

# 33-DIS-1R25 S

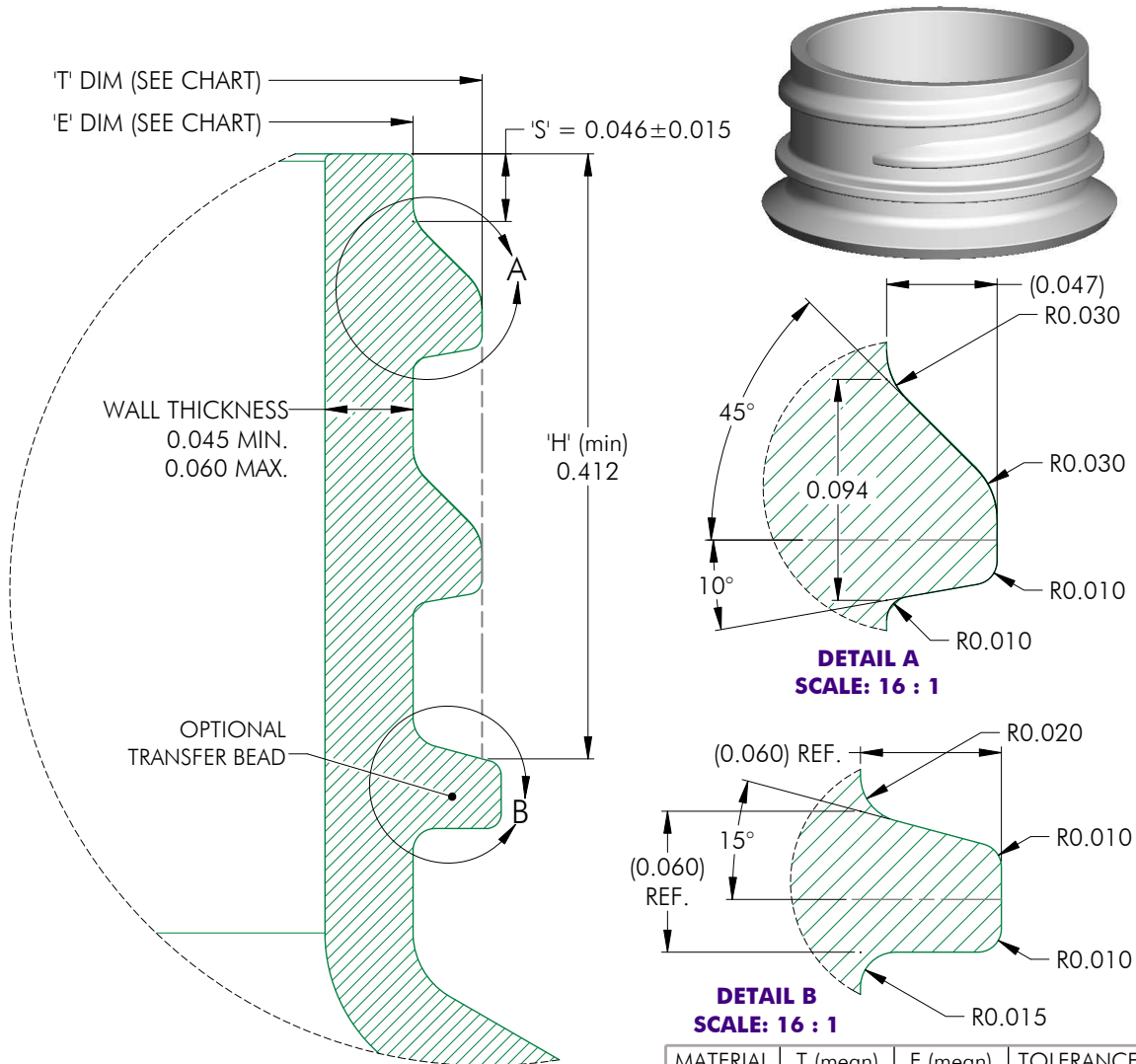

MATERIAL	T (mean)	E (mean)	TOLERANCE
PP / PE	1.253	1.159	± 0.012
PET	1.257	1.163	± 0.008
GLASS	0.0000	0.0000	± 0.0000

<p>NOTES: (UNLESS OTHERWISE SPECIFIED)                  1. ALL DIMENSIONS ARE IN INCHES.                  2. SEE CHART FOR DIMENSIONAL TOLERANCE.</p> <p>THIS OR FACSIMILE THEREOF IS THE EXCLUSIVE PROPERTY OF PHOENIX AND MAY NOT BE REPRODUCED WITHOUT THE EXPRESSED WRITTEN CONSENT OF PHOENIX. SOME OR ALL OF THE ITEMS DEPICTED ON THIS DRAWING MAY BE COVERED BY CURRENT PATENTS OR PATENTS APPLIED FOR BY PHOENIX.</p>	1	03.13.17	Update wall thickness to reflect Market	DN	
	REV	DATE	DESCRIPTION	BY	
	TOLERANCE	PITCH/TP/1.167 / 6	TURNS 1-1/8	MAT'L PER CHART	
	.X ±0.1	DRAWN DMN	DATE 03.13.17	SCALE 10 : 1	REV
	.XX ±0.02	<b>33 - 400 - FINISH</b>			1