

# 33-DIS-1R19 S



## Specifications:

<b>DIAMETER</b>	33 mm
<b>NECK FINISH</b>	33-400
<b>CLOSURE TYPE</b>	Dispensing
<b>CLOSURE TOP</b>	Smooth Flip-Top
<b>CLOSURE SIDEWALL</b>	Ribbed
<b>ORIFICE</b>	0.18"
<b>MATERIAL</b>	PP

### PACKAGING & FREIGHT INFORMATION

PACK TYPE	PCS/CTN	CTNS/PALT	PCS/PALT	CTN WT*	PALT WT*	FRT CLASS
Bulk	2,500	15	37,500	28.6 <sup>(1)</sup>	430 <sup>(1)</sup>	125 <sup>(1)</sup>
Bulk	2,500	15	37,500	29.7 <sup>(2)</sup>	446 <sup>(2)</sup>	100 <sup>(2)</sup>
<b>CARTON DIMENSIONS: 24 x 16 x 15</b>			<b>PALLET DIMENSIONS: 48 x 40 x 50</b>			

(1) Unlined Closures (2) Lined Closures \*Approximate

### MARKETS

Dressings & Sauces, Honey, Jams and Jellies, Condiments, Lotions, Cleansers, Cleaning Products

### OPTIONS

Available in white, standard, and custom colors. Can be lined with a wide variety of liner systems.

### CLOSURE BENEFITS

- MESA flip-top dispensing closure
- Easy dispensing & clean flow
- Audible “click” indicates security
- Single-wall design

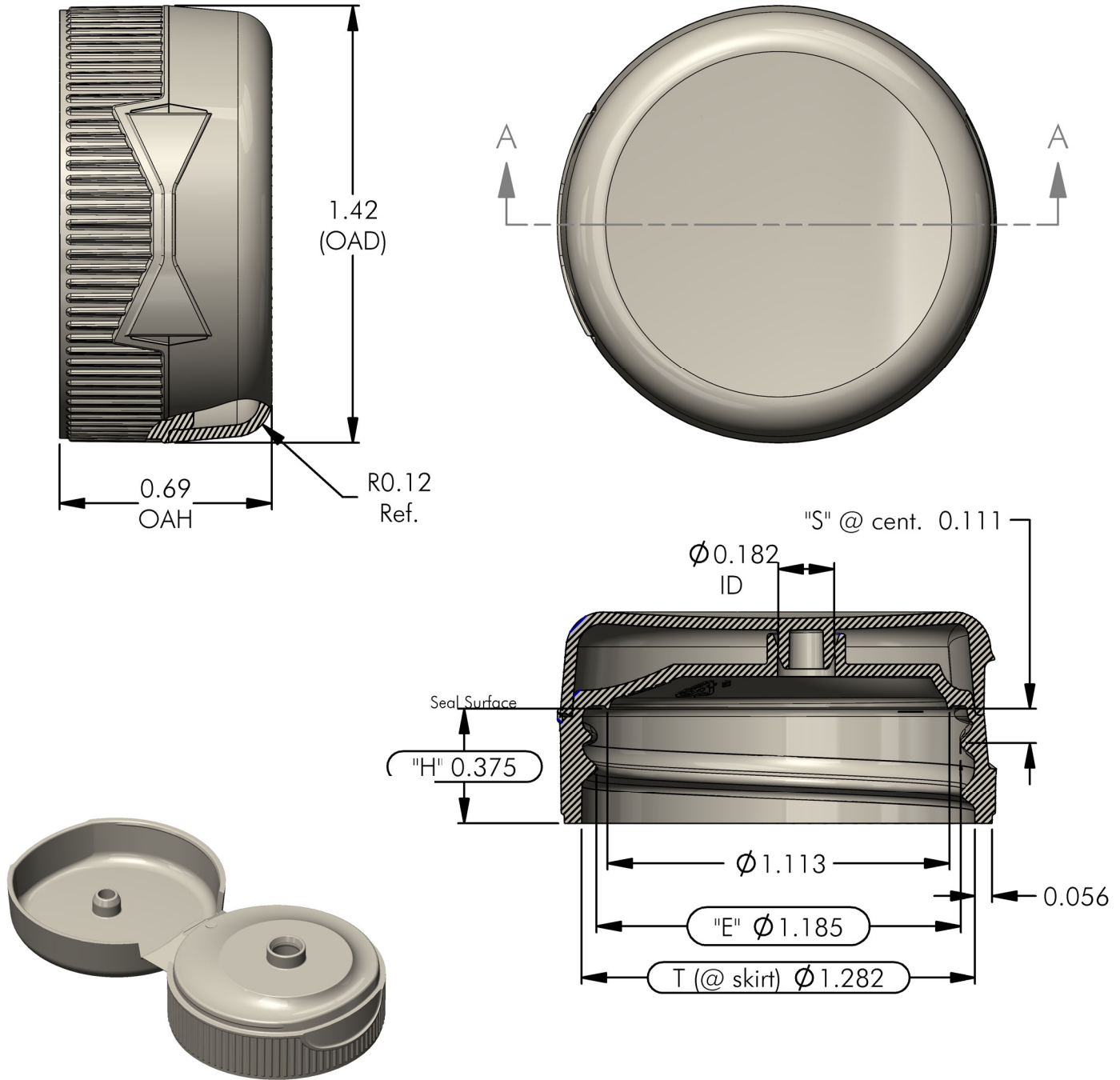

4.227

NOTES: (UNLESS OTHERWISE SPECIFIED) 1. ALL DIMENSIONS ARE IN INCHES. 2. SEE CHART FOR DIMENSIONAL TOLERANCE.  THIS OR FACSIMILE THEREOF IS THE EXCLUSIVE PROPERTY OF PHOENIX AND MAY NOT BE REPRODUCED WITHOUT THE EXPRESSED WRITTEN CONSENT OF PHOENIX. SOME OR ALL OF THE ITEMS DEPICTED ON THIS DRAWING MAY BE COVERED BY CURRENT PATENTS OR PATENTS APPLIED FOR BY PHOENIX.	-	00.00.00	-	-					
	REV	DATE	DESCRIPTION	BY					
	TOLERANCE	PITCH/TPI	.167 / 6	TURNS	1-1/8	MAT'L	PP		
	.X	±0.1	DRAWN	TCS	DATE	11.02.20	SCALE	2 : 1	REV
.XX	±0.02	033 - DIS - 1R19 S							0
.XXX	±0.010								



PHXPKG.COM

P 630 420 4750 E greatpkg@phxpkg.com  
 975 Meridian Lake Drive • Aurora, IL 60504

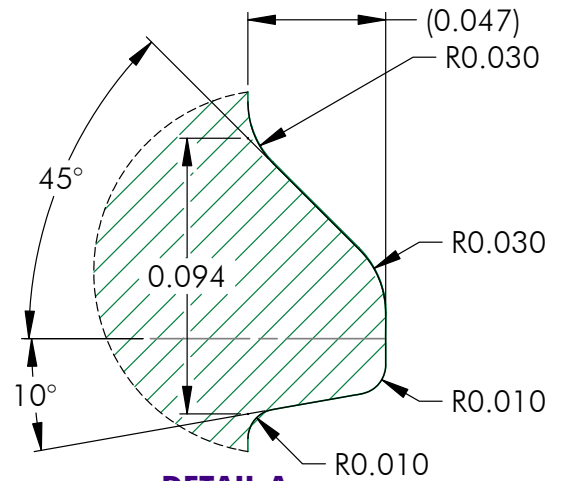
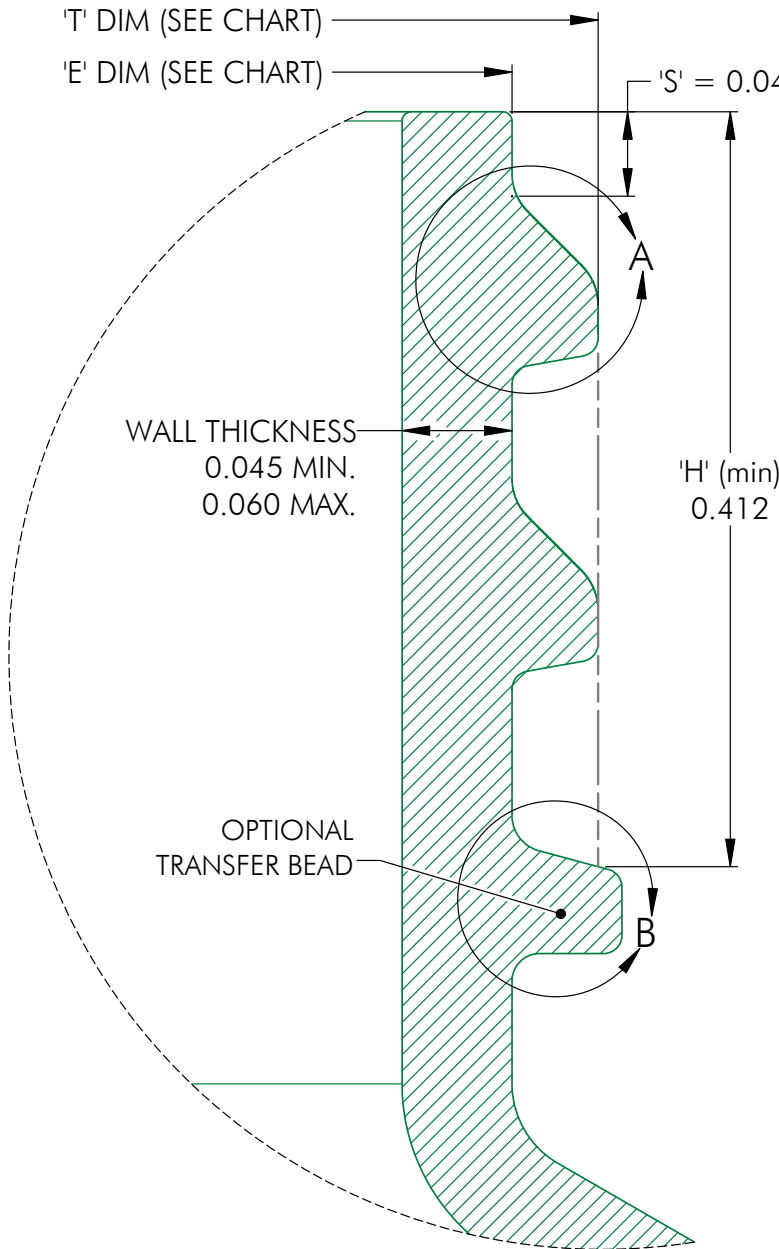
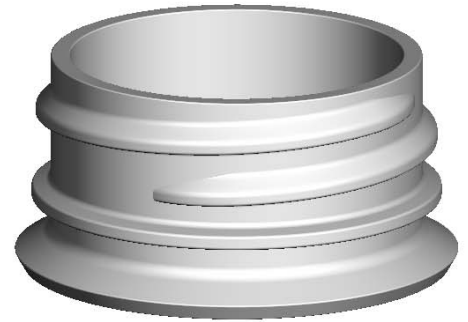

**DETAIL A**  
SCALE: 16 : 1

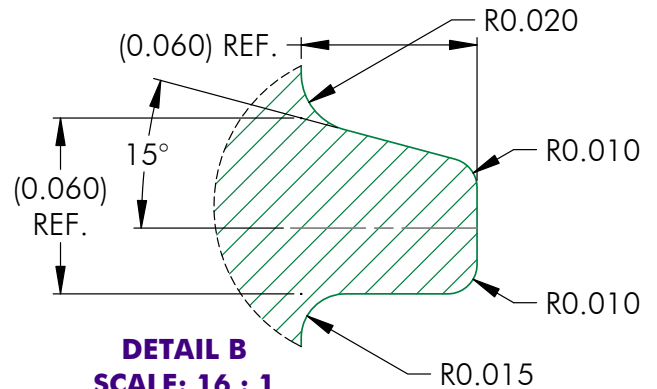

**DETAIL B**  
SCALE: 16 : 1

MATERIAL	T (mean)	E (mean)	TOLERANCE
PP / PE	1.253	1.159	± 0.012
PET	1.257	1.163	± 0.008
GLASS	0.0000	0.0000	± 0.0000

NOTES: (UNLESS OTHERWISE SPECIFIED)  
1. ALL DIMENSIONS ARE IN INCHES.  
2. SEE CHART FOR DIMENSIONAL TOLERANCE.

1	03.13.17	Update wall thickness to reflect Market		DN
REV	DATE	DESCRIPTION		BY
TOLERANCE		PITCH/TPI .167 / 6	URNS 1-1/8	MAT'L PER CHART
.X	±0.1	DRAWN DMN	DATE 03.13.17	SCALE 10 : 1
.XX	±0.02	<b>33 - 400 - FINISH</b>		REV
.XXX	±0.010			1

THIS OR FACSIMILE THEREOF IS THE EXCLUSIVE PROPERTY OF PHOENIX AND MAY NOT BE REPRODUCED WITHOUT THE EXPRESSED WRITTEN CONSENT OF PHOENIX. SOME OR ALL OF THE ITEMS DEPICTED ON THIS DRAWING MAY BE COVERED BY CURRENT PATENTS OR PATENTS APPLIED FOR BY PHOENIX.



PHXPKG.COM

P 630 420 4750 E greatpkg@phxpkg.com  
975 Meridian Lake Drive • Aurora, IL 60504