

MEDIUM & DEEP SKIRT CLOSURES

# 33-8TP-DS S



## Specifications:

**DIAMETER** 33 mm  
**THREAD PROFILE** 8TP  
**NECK FINISH** 33-8TP  
**CLOSURE TYPE** CT  
**CLOSURE TOP** Smooth  
**CLOSURE SIDEWALL** Smooth  
**MATERIAL** PP

### PACKAGING & FREIGHT INFORMATION

PACK TYPE	PCS/CTN	CTNS/PALT	PCS/PALT	CTN WT*	PALT WT*	FRT CLASS
Bulk	3,500	15	52,500	29.1 <sup>(1)</sup>	437 <sup>(1)</sup>	125 <sup>(1)</sup>
Bulk	3,500	15	52,500	31.4 <sup>(1)</sup>	470 <sup>(1)</sup>	100 <sup>(1)</sup>
<b>CARTON DIMENSIONS: 24 x 16 x 15</b>			<b>PALLET DIMENSIONS: 48 x 40 x 50</b>			

(1) Unlined Closures (2) Lined Closures \*Approximate

### MARKETS

Dressings & Sauces, Food, Food Service, and Food Oil

### OPTIONS

Available in white, standard, and custom colors. Can be lined with a wide variety of liner systems.

### CLOSURE BENEFITS

- Popular for salad dressings
- Popular for sauces
- Smooth top & sides lend a clean look to the product

**MEDIUM & DEEP SKIRT CLOSURES**

# 33-8TP-DS S

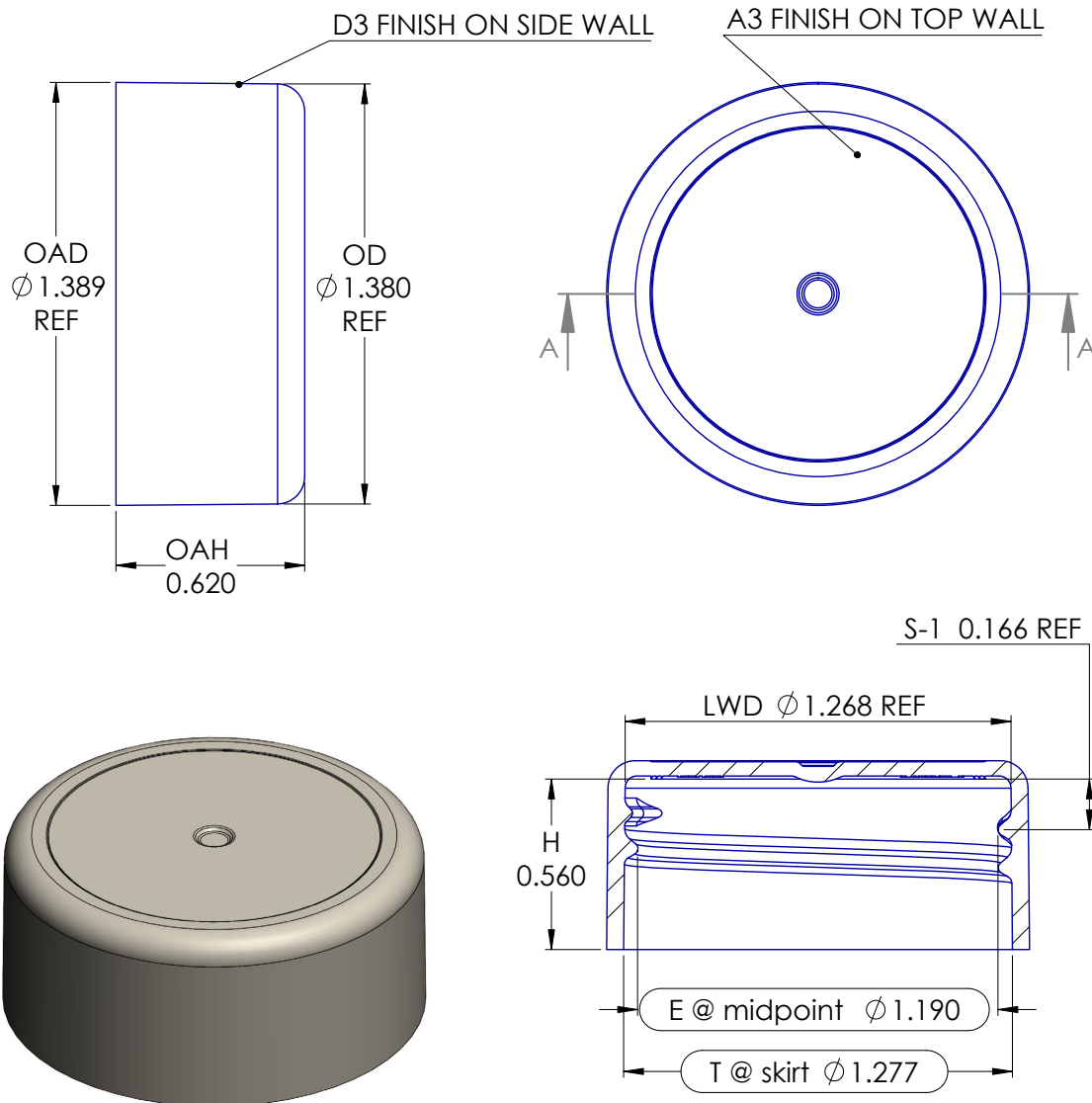

NOTES: (UNLESS OTHERWISE SPECIFIED)  
 1. ALL DIMENSIONS ARE IN INCHES.  
 2. SEE CHART FOR DIMENSIONAL TOLERANCE.

THIS OR FACSIMILE THEREOF IS THE EXCLUSIVE PROPERTY OF PHOENIX AND MAY NOT BE REPRODUCED WITHOUT THE EXPRESSED WRITTEN CONSENT OF PHOENIX. SOME OR ALL OF THE ITEMS DEPICTED ON THIS DRAWING MAY BE COVERED BY CURRENT PATENTS OR PATENTS APPLIED FOR BY PHOENIX.

1	12.03.20	Updated E dimension and side wall finish		LD
REV	DATE	DESCRIPTION		BY
TOLERANCE	PITCH/TPI	.125 / 0	TURNS	1 1/4
.X	±0.1	MAT'L	PP	
.XX	±0.02	DRAWN	LMD	DATE 05.01.20
.XXX	±0.010	SCALE	2 : 1	REV
<b>033 - 8TP - DS S</b>				<b>1</b>

MEDIUM & DEEP SKIRT CLOSURES

# 33-8TP-DS S

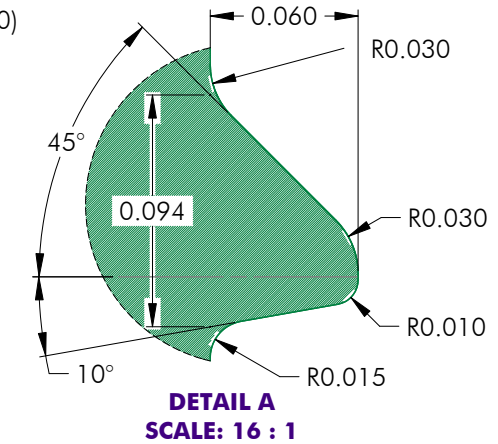
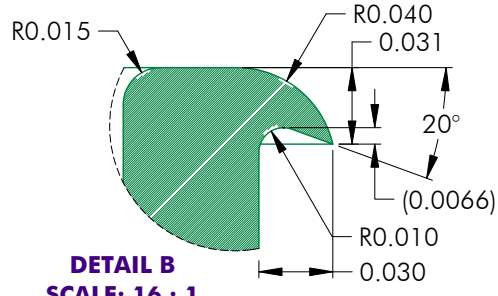
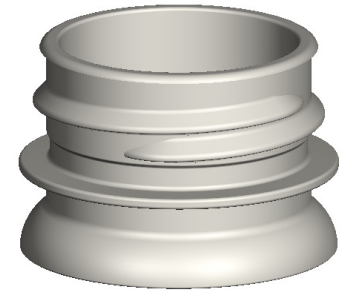
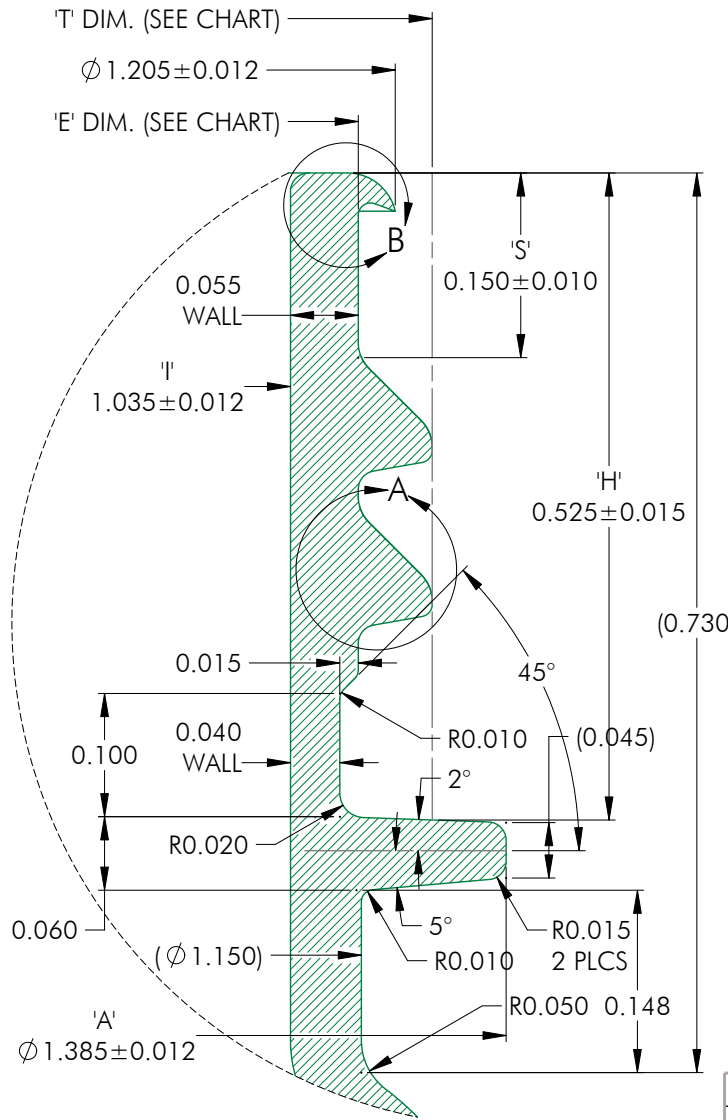

MATERIAL	T (mean)	E (mean)	TOLERANCE
PP / PE	1.265	1.145	± 0.012
PET	1.265	1.145	± 0.012
GLASS	N/A	N/A	N/A

NOTES: (UNLESS OTHERWISE SPECIFIED) 1. ALL DIMENSIONS ARE IN INCHES. 2. SEE CHART FOR DIMENSIONAL TOLERANCE.  THIS OR FACSIMILE THEREOF IS THE EXCLUSIVE PROPERTY OF PHOENIX AND MAY NOT BE REPRODUCED WITHOUT THE EXPRESSED WRITTEN CONSENT OF PHOENIX. SOME OR ALL OF THE ITEMS DEPICTED ON THIS DRAWING MAY BE COVERED BY CURRENT PATENTS OR PATENTS APPLIED FOR BY PHOENIX.	0	05.06.15	Released	DN					
	REV	DATE	DESCRIPTION	BY					
	TOLERANCE	PITCH/TPI	.125 / 8	TURNS	1-1/8	MAT'L	PER CHART		
	.X	±0.1	DRAWN	DMN	DATE	05.06.15	SCALE	8 : 1	REV

**33 - 8TP - FINISH**