

SHALLOW SKIRTED CLOSURES

33-400-6213 S



Specifications:

DIAMETER 33 mm
THREAD PROFILE 400
NECK FINISH 33-400
CLOSURE TOP Stipple
CLOSURE SIDEWALL Fine Ribbed
MATERIAL PP

PACKAGING & FREIGHT INFORMATION

PACK TYPE	PCS/CTN	CTNS/PALT	PCS/PALT	CTN WT*	PALT WT*	FRT CLASS
Bulk	5,000	15	75,000	27 ⁽¹⁾	404 ⁽¹⁾	100 ⁽¹⁾
Bulk	5,000	15	75,000	30 ⁽²⁾	405 ⁽²⁾	100 ⁽²⁾
CARTON DIMENSIONS: 24 x 16 x 15			PALLET DIMENSIONS: 48 x 40 x 50			

(1) Unlined Closures (2) Lined Closures *Approximate

MARKETS

Agricultural, Automotive, Industrial, and Medical Products, Dressings & Sauces, Food, Food Oil & Service, Personal Care & Cosmetics, Pharmaceuticals, Beverages, Household Chemicals, Nutraceuticals, and Dairy Products

OPTIONS

Available in white, standard, and custom colors.
 Liners can be cut with tri-tab easy-open feature.
 Can be embossed/debossed with custom message.

CLOSURE BENEFITS

- A great general-purpose closure
- A proven closure for the Food Oil and Agricultural Chemical markets
- Fine-ribbed sides are easier to grip
- Popular for cosmetics

SHALLOW SKIRTED CLOSURES

33-400-6213 S

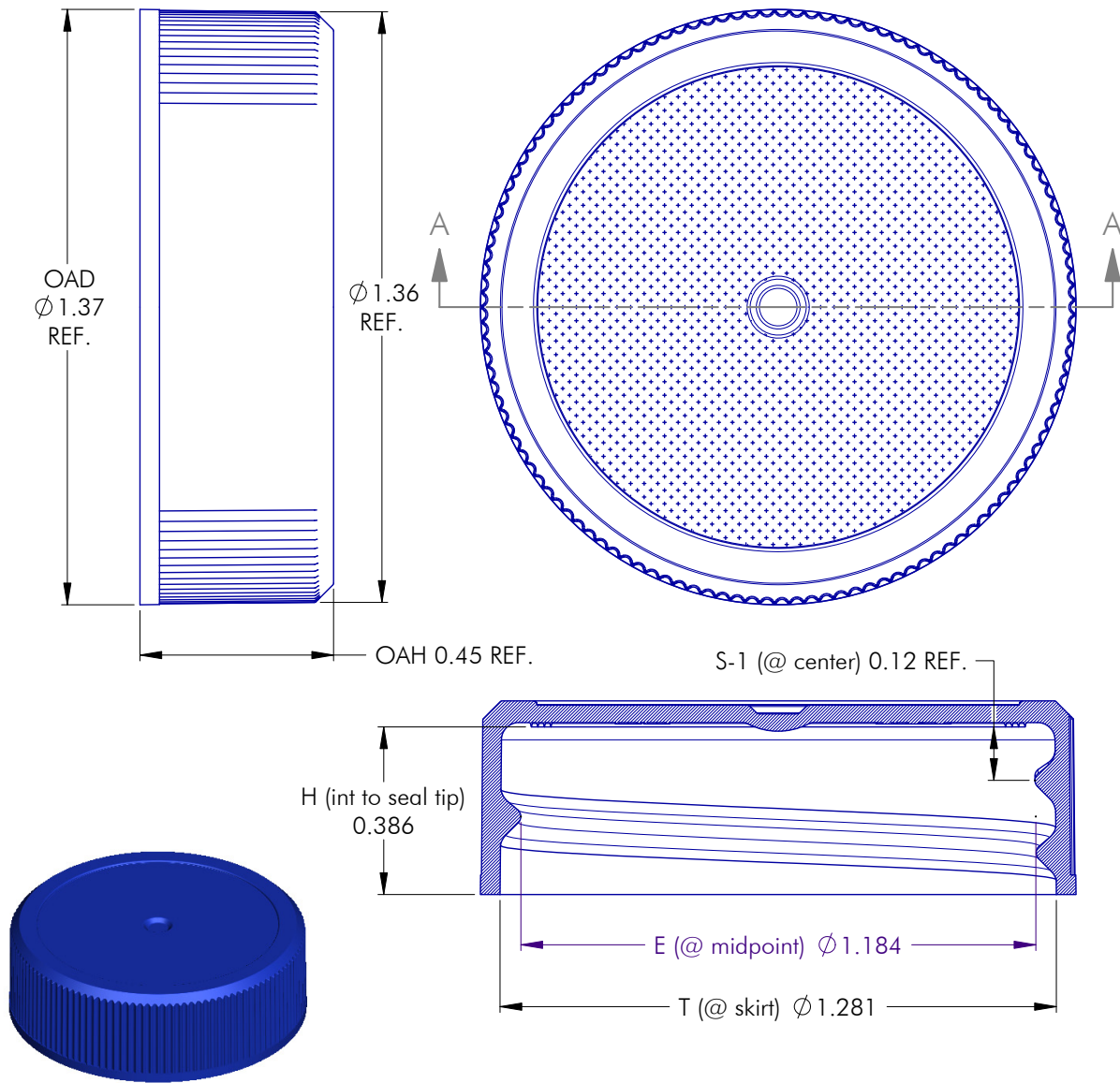

NOTES: (UNLESS OTHERWISE SPECIFIED)
 1. ALL DIMENSIONS ARE IN INCHES.
 2. SEE CHART FOR DIMENSIONAL TOLERANCE.

THIS OR FACSIMILE THEREOF IS THE EXCLUSIVE PROPERTY OF PHOENIX AND MAY NOT BE REPRODUCED WITHOUT THE EXPRESSED WRITTEN CONSENT OF PHOENIX. SOME OR ALL OF THE ITEMS DEPICTED ON THIS DRAWING MAY BE COVERED BY CURRENT PATENTS OR PATENTS APPLIED FOR BY PHOENIX.

4	09.30.21	Updated Interior Engraving			LD
REV	DATE	DESCRIPTION			BY
TOLERANCE	PITCH/TPI	.167 / 6	TURNS	1-1/8	MAT'L PP
.X ±0.1	DRAWN	DMN	DATE	04.02.08	SCALE 3 : 1
.XX ±0.02	033 - 400 - 6213 S			REV	4
.XXX ±0.010					

SHALLOW SKIRTED CLOSURES

33-400-6213 S

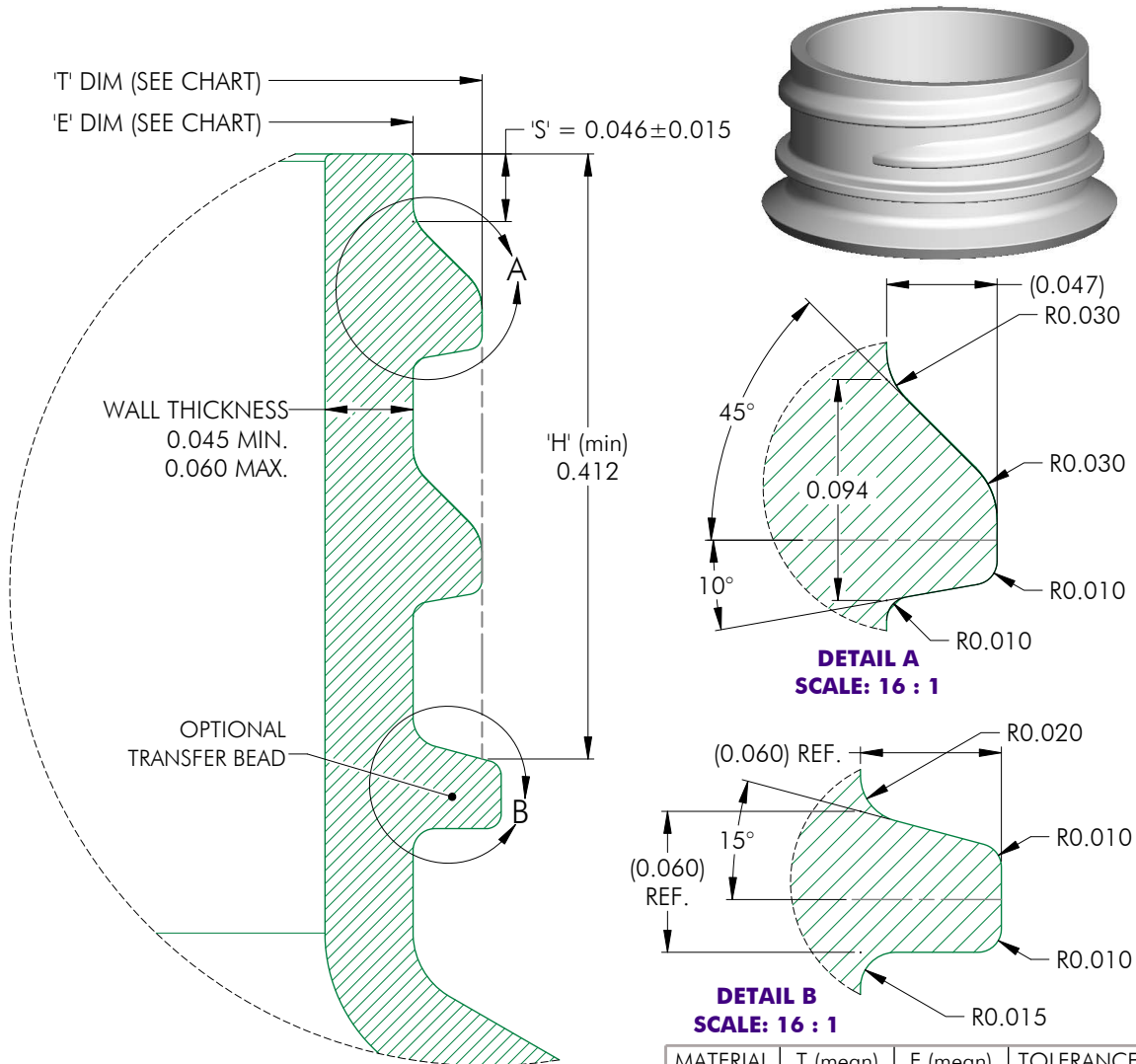

MATERIAL	T (mean)	E (mean)	TOLERANCE
PP / PE	1.253	1.159	± 0.012
PET	1.257	1.163	± 0.008
GLASS	0.0000	0.0000	± 0.0000

NOTES: (UNLESS OTHERWISE SPECIFIED) 1. ALL DIMENSIONS ARE IN INCHES. 2. SEE CHART FOR DIMENSIONAL TOLERANCE. THIS OR FACSIMILE THEREOF IS THE EXCLUSIVE PROPERTY OF PHOENIX AND MAY NOT BE REPRODUCED WITHOUT THE EXPRESSED WRITTEN CONSENT OF PHOENIX. SOME OR ALL OF THE ITEMS DEPICTED ON THIS DRAWING MAY BE COVERED BY CURRENT PATENTS OR PATENTS APPLIED FOR BY PHOENIX.	1	03.13.17	Update wall thickness to reflect Market	DN
	REV	DATE	DESCRIPTION	BY
	TOLERANCE	PITCH/TP/1.167 / 6 TURNS 1-1/8		MAT'L PER CHART
	.X ±0.1	DRAWN DMN	DATE 03.13.17	SCALE 10 : 1
	.XX ±0.02	33 - 400 - FINISH		
.XXX ±0.010				1