

28-DIS-CS13 U



Specifications:

DIAMETER	28 mm
NECK FINISH	28-410
CLOSURE TYPE	Flip-top dispensing
CLOSURE TOP	Smooth
CLOSURE SIDEWALL	Smooth
MATERIAL	PP, PCR PP
ORIFICE	0.125"

PACKAGING & FREIGHT INFORMATION

PACK TYPE	PCS/CTN	CTNS/PALT	PCS/PALT	CTN WT*	PALT WT*	FRT CLASS
Bulk	3,100	15	46,500	28 ⁽¹⁾	449 ⁽¹⁾	100 ⁽¹⁾
CARTON DIMENSIONS: 24 x 16 x 15			PALLET DIMENSIONS: 48 x 40 x 50			

(1) Unlined Closures (2) Lined Closures *Approximate

MARKETS

Hand Sanitizer, Liquid Soaps, Shampoos, Skin Care, Gels, Lotions, Food, Syrup, Honey, Cleansers, Cleaning Liquids

OPTIONS

Available in white, standard, and custom colors. Leak-free linerless and liner options. PCR material available for non-food up to 100%.

CLOSURE BENEFITS

- Oasis Flip-Top Dispensing Closure with 0.125" orifice
- Crab-claw linerless seal
- Smooth gloss finish
- Leak-free design
- Popular for hand sanitizers
- Popular for personal care items



PHXPKG.COM

P 630 420 4750 E greatpkg@phxpkg.com
975 Meridian Lake Drive • Aurora, IL 60504

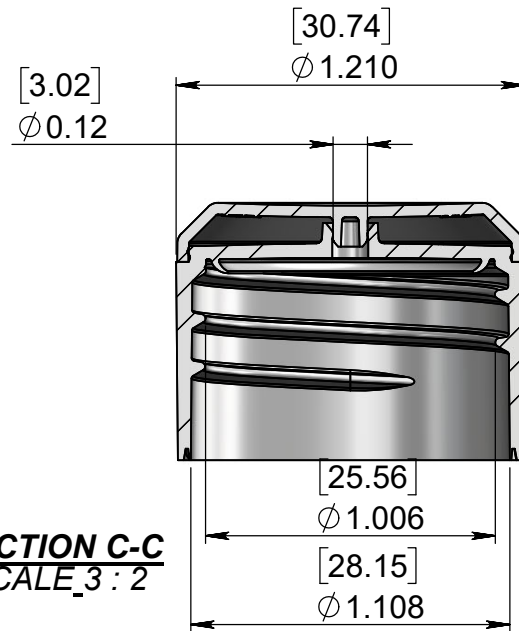
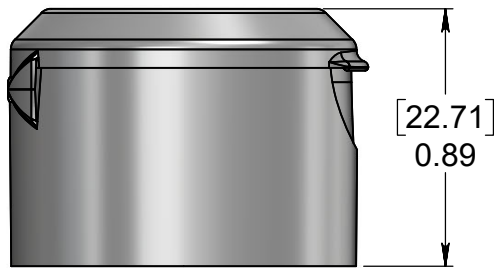
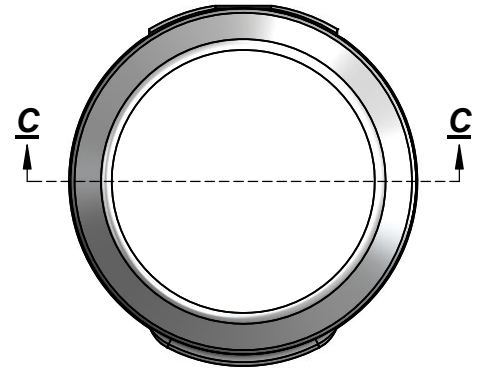

SECTION C-C
SCALE 3 : 2

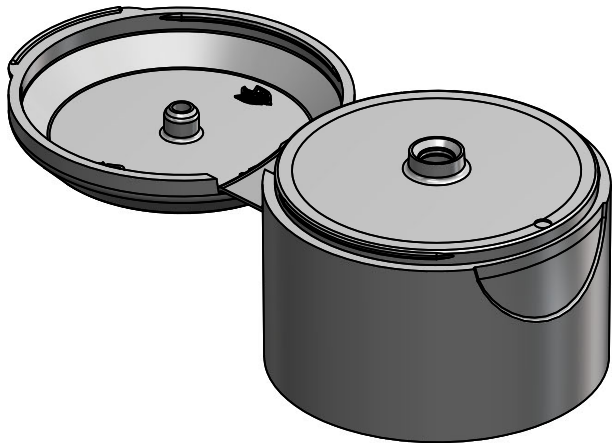

NOTES: (UNLESS OTHERWISE SPECIFIED) 1. ALL DIMENSIONS ARE IN INCHES. 2. SEE CHART FOR DIMENSIONAL TOLERANCE. THIS OR FACSIMILE THEREOF IS THE EXCLUSIVE PROPERTY OF PHOENIX AND MAY NOT BE REPRODUCED WITHOUT THE EXPRESSED WRITTEN CONSENT OF PHOENIX. SOME OR ALL OF THE ITEMS DEPICTED ON THIS DRAWING MAY BE COVERED BY CURRENT PATENTS OR PATENTS APPLIED FOR BY PHOENIX.	D	04.20.20	Finalize Design, Add PCI Logo		TCS	
	REV	DATE	DESCRIPTION		BY	
	TOLERANCE	PITCH/TPI .167 / 6		TURN	1	MAT'L PP
	.X	±0.1	DRAWN	RAG	DATE 04.16.20	SCALE 1.5 : 1
.XX	±0.02	028 - DIS - CS13 U				D
.XXX	±0.010					

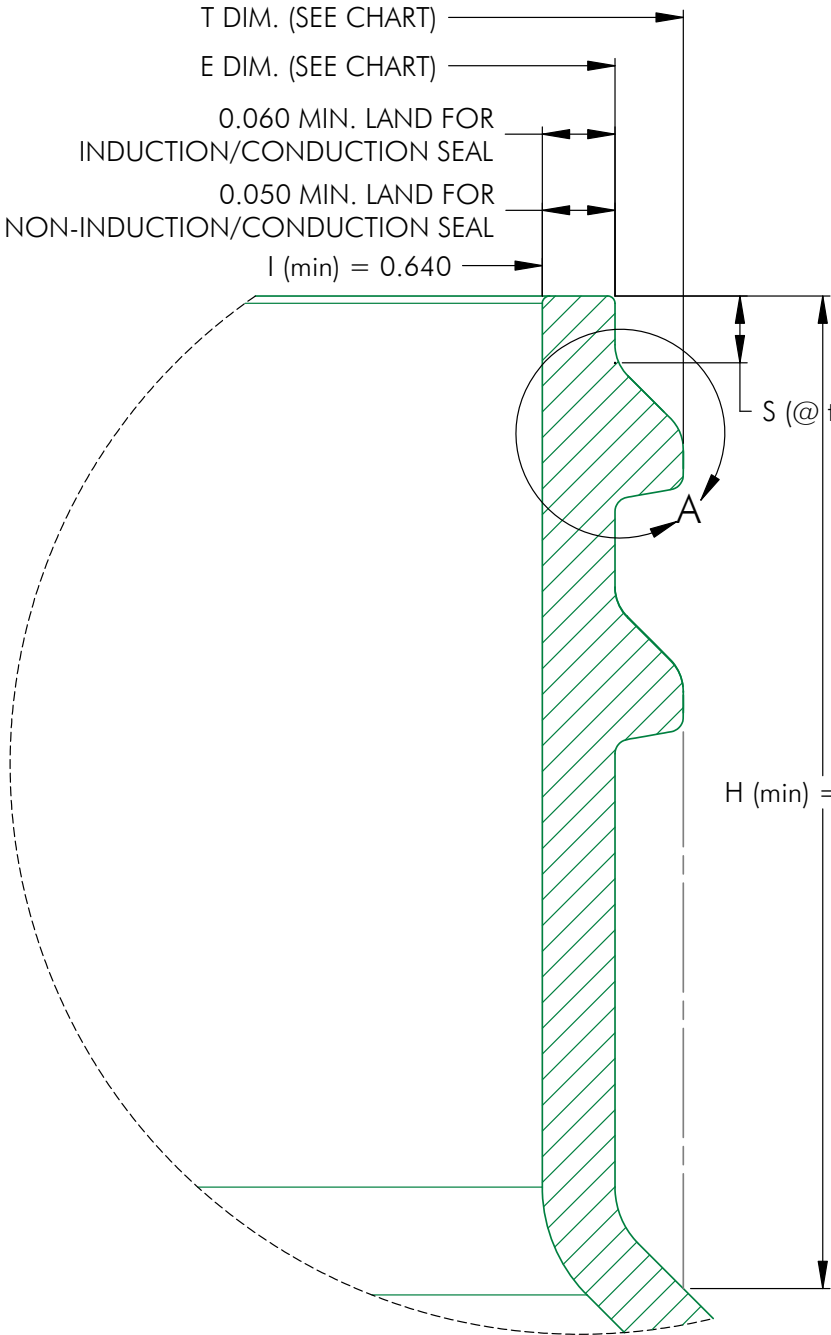

MATERIAL	T (mean)	E (mean)	TOLERANCE
PP / PE	1.078	0.984	± 0.010
PET	1.078	0.984	± 0.006
GLASS	N/A	N/A	± N/A

NOTES: (UNLESS OTHERWISE SPECIFIED) 1. ALL DIMENSIONS ARE IN INCHES. 2. SEE CHART FOR DIMENSIONAL TOLERANCE. THIS OR FACSIMILE THEREOF IS THE EXCLUSIVE PROPERTY OF PHOENIX AND MAY NOT BE REPRODUCED WITHOUT THE EXPRESSED WRITTEN CONSENT OF PHOENIX. SOME OR ALL OF THE ITEMS DEPICTED ON THIS DRAWING MAY BE COVERED BY CURRENT PATENTS OR PATENTS APPLIED FOR BY PHOENIX.	0	10.19.18	Released	BZ	
	REV	DATE	DESCRIPTION	BY	
	TOLERANCE	PITCH/TPI .167 / 6		TURNS 1-1/4	MAT'L PER CHART
	.X ±0.1	DRAWN BEZ	DATE 10.19.04	SCALE 8 : 1	REV
	.XX ±0.02	28 - 410 - FINISH			0
.XXX ±0.010					