

VISTA CHILD-RESISTANT CLOSURES

28-CRC-STPT A



Specifications:

DIAMETER 28 mm

THREAD PROFILE CRC

NECK FINISH 28-CRC

CLOSURE TOP Debossed Pictogram

CLOSURE SIDEWALL Wide Ribbed

MATERIAL PP, PCR PP

PACKAGING & FREIGHT INFORMATION

PACK TYPE	PCS/CTN	CTNS/PALT	PCS/PALT	CTN WT*	PALT WT*	FRT CLASS
Bulk	3,000	15	45,000	34.4 ⁽¹⁾	516 ⁽¹⁾	100 ⁽¹⁾
Bulk	3,000	15	45,000	35.6 ⁽²⁾	534 ⁽²⁾	100 ⁽²⁾
CARTON DIMENSIONS: 24 x 16 x 15			PALLET DIMENSIONS: 48 x 40 x 50			

(1) Unlined Closures (2) Lined Closures *Approximate

MARKETS

Vitamins, Nutraceuticals, Pharmaceuticals, Supplements, Agricultural Products, Automotive Products, Household Chemicals, Cosmetics, Industrial Products, Cannabis, and Nutritional Powders

OPTIONS

Available in white, standard, and custom colors. Can be lined with a wide variety of liner systems including SureSeal (foam). Optional 25-30% food-contact safe PCR PP material available.

CLOSURE BENEFITS

- Offers child-resistance feature
- Vista® 2-piece CRC
- Push-and-turn
- Debossed with pictogram
- Popular for vitamins & nutraceuticals



PHXPKG.COM

P 630 420 4750 E greatpkg@phxpkg.com
975 Meridian Lake Drive • Aurora, IL 60504

VISTA CHILD-RESISTANT CLOSURES

28-CRC-STPT A

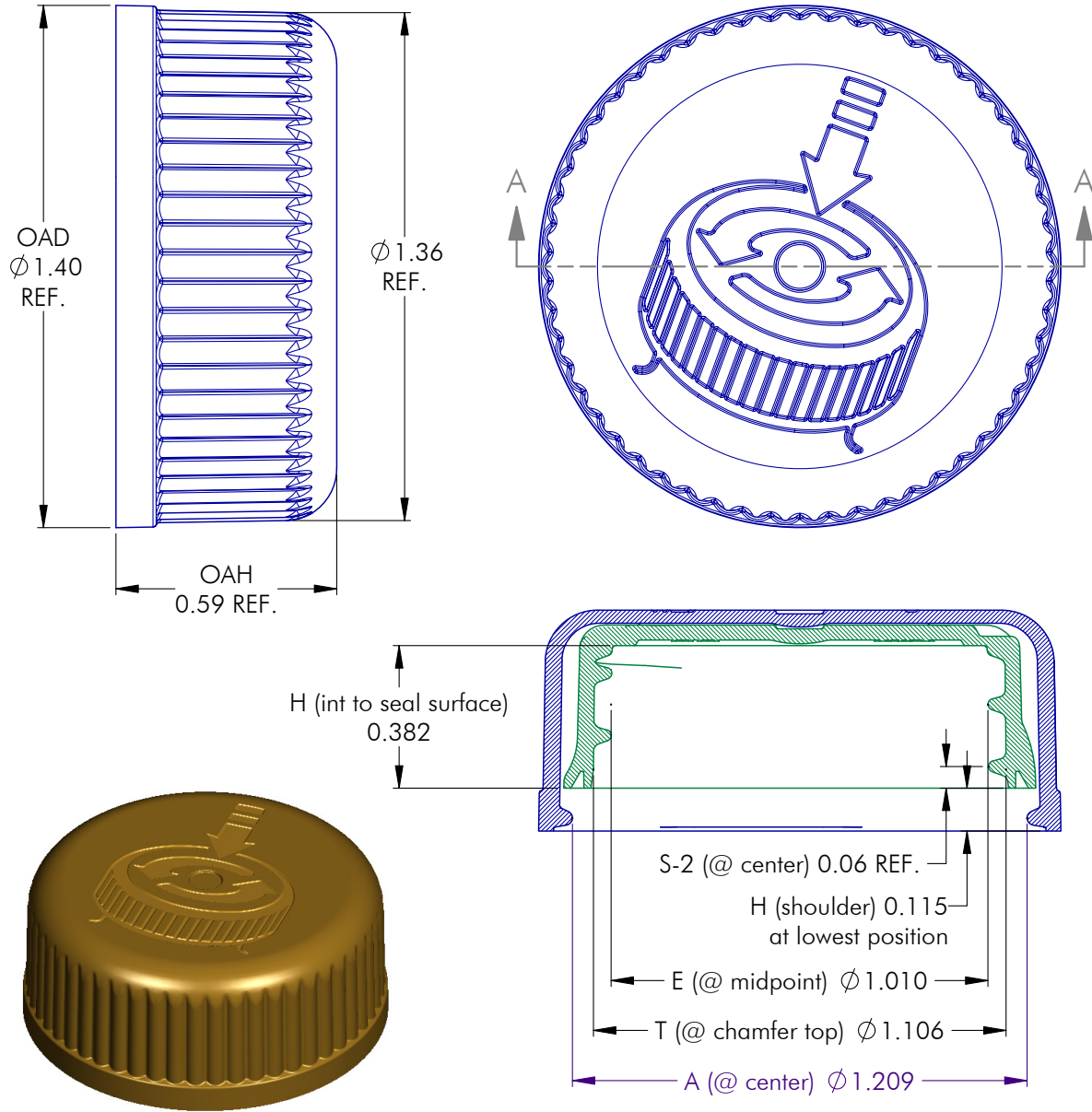

NOTES: (UNLESS OTHERWISE SPECIFIED)
 1. ALL DIMENSIONS ARE IN INCHES.
 2. SEE CHART FOR DIMENSIONAL TOLERANCE.

THIS OR FACSIMILE THEREOF IS THE EXCLUSIVE PROPERTY OF PHOENIX AND MAY NOT BE REPRODUCED WITHOUT THE EXPRESSED WRITTEN CONSENT OF PHOENIX. SOME OR ALL OF THE ITEMS DEPICTED ON THIS DRAWING MAY BE COVERED BY CURRENT PATENTS OR PATENTS APPLIED FOR BY PHOENIX.

7	03.19.21	Update "E" Dim. to Reflect Production	DN
REV	DATE	DESCRIPTION	BY
TOLERANCE	PITCH/TPI .167 / 6	TURNS ~1-1/4	MAT'L PP
.X ±0.1	DRAWN DMN	DATE 09.08.16	SCALE 5 : 2
.XX ±0.02	28 - CRC - STPT S		REV
.XXX ±0.010			7



PHOENIX™

PHXPKG.COM

 P 630 420 4750 E greatpkg@phxpkg.com
 975 Meridian Lake Drive • Aurora, IL 60504

VISTA CHILD-RESISTANT CLOSURES

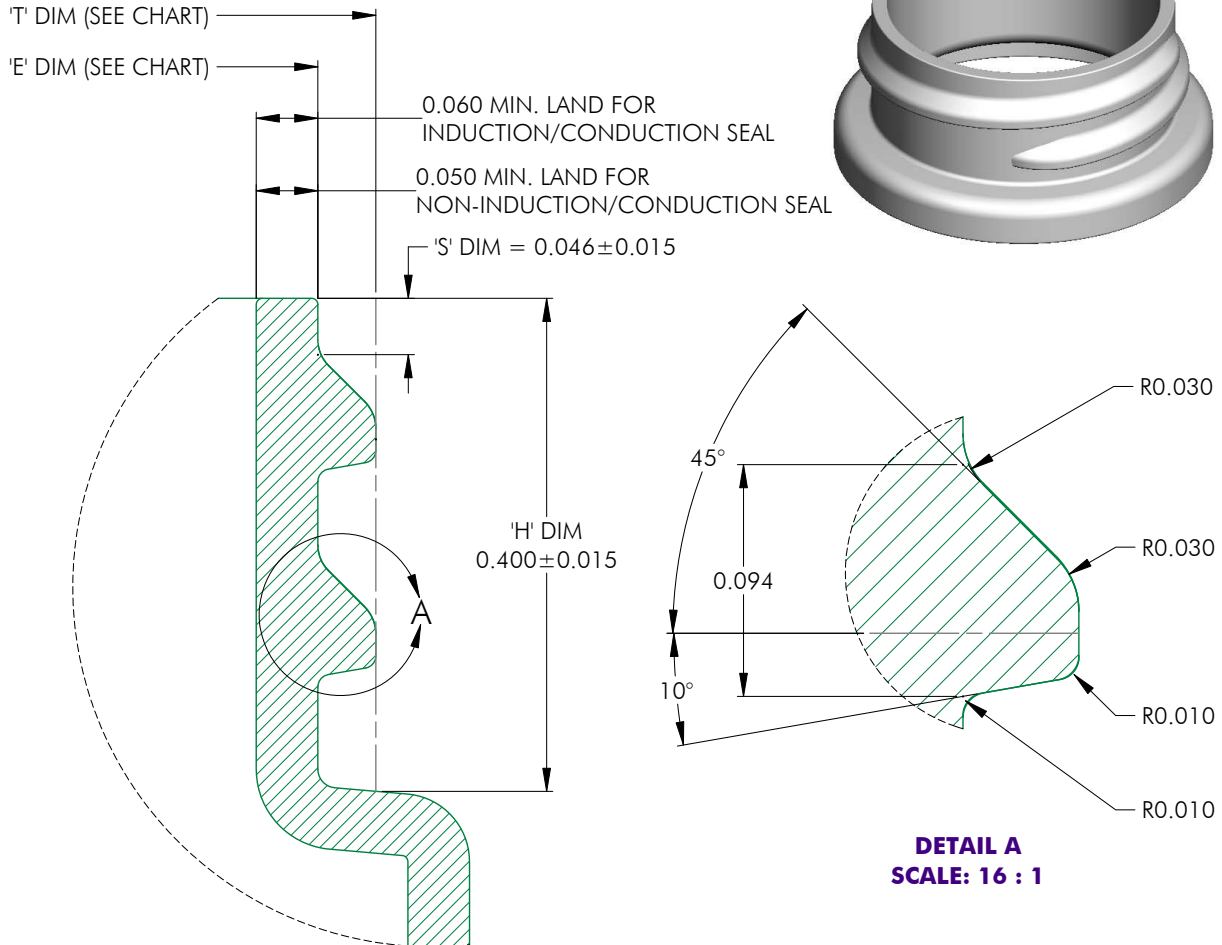
28-CRC-STPT A



DETAIL A
SCALE: 16 : 1

MATERIAL	T (mean)	E (mean)	TOLERANCE
PP / PE	1.078	0.984	± 0.010
PET	1.080	0.986	± 0.008
GLASS	N/A	N/A	± N/A

NOTES: (UNLESS OTHERWISE SPECIFIED) 1. ALL DIMENSIONS ARE IN INCHES. 2. SEE CHART FOR DIMENSIONAL TOLERANCE. THIS OR FACSIMILE THEREOF IS THE EXCLUSIVE PROPERTY OF PHOENIX AND MAY NOT BE REPRODUCED WITHOUT THE EXPRESSED WRITTEN CONSENT OF PHOENIX. SOME OR ALL OF THE ITEMS DEPICTED ON THIS DRAWING MAY BE COVERED BY CURRENT PATENTS OR PATENTS APPLIED FOR BY PHOENIX.	0	11.15.04	Released	BZ			
	REV	DATE	DESCRIPTION	BY			
	TOLERANCE	PITCH/TPI	.167 / 6	TURNS	1-1/8	MAT'L	PER CHART
	.X ±0.1	DRAWN	BEZ	DATE	11.15.04	SCALE	8 : 1
.XX ±0.02	28 - 400 - FINISH						0
.XXX ±0.010							