

SHALLOW SKIRTED CLOSURES

28-400-62 S



Specifications:

DIAMETER 28 mm
THREAD PROFILE 400
NECK FINISH 28-400
CLOSURE TOP Stipple
CLOSURE SIDEWALL Fine Ribbed
MATERIAL PP

PACKAGING & FREIGHT INFORMATION

PACK TYPE	PCS/CTN	CTNS/PALT	PCS/PALT	CTN WT*	PALT WT*	FRT CLASS
Bulk	6,250	15	93,750	33 ⁽¹⁾	491 ⁽¹⁾	100 ⁽¹⁾
Bulk	6,250	15	93,750	36 ⁽²⁾	535 ⁽²⁾	92.5 ⁽²⁾
CARTON DIMENSIONS: 24 x 16 x 15			PALLET DIMENSIONS: 48 x 40 x 50			

(1) Unlined Closures (2) Lined Closures *Approximate

MARKETS

Automotive and Medical Products, Household Chemicals, Cosmetics, Food, Personal Care, and Pharmaceuticals

OPTIONS

Available in white, standard colors and custom colors. Can be lined with a wide variety of liner systems including SureSeal (foam), pressure sensitive and heat induction (foil) liners.

CLOSURE BENEFITS

- A great general-purpose closure
- Fine-ribbed sides are easier to grip
- Popular for cosmetics
- Our most popular closure style

SHALLOW SKIRTED CLOSURES

28-400-62 S

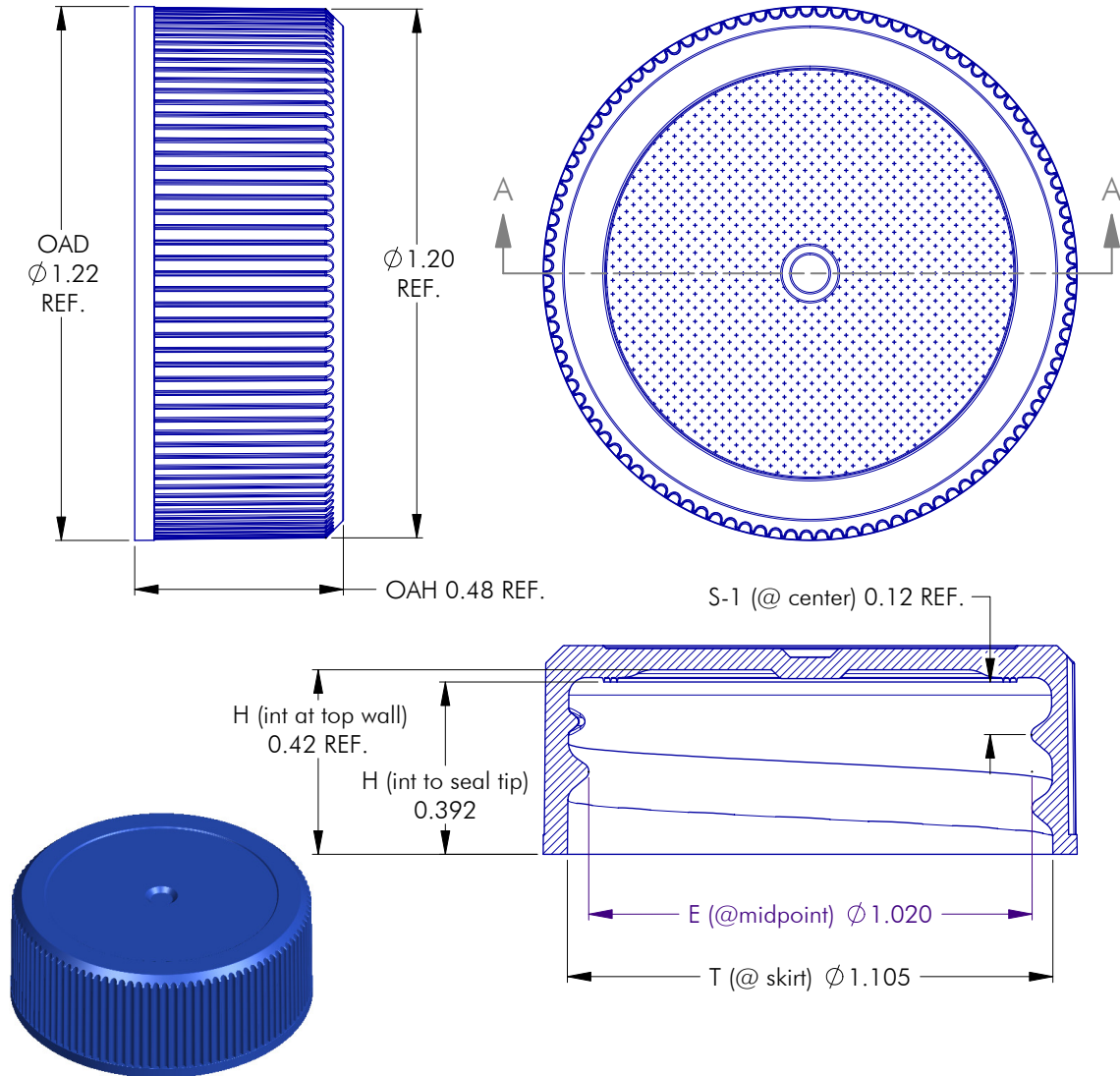

NOTES: (UNLESS OTHERWISE SPECIFIED)

1. ALL DIMENSIONS ARE IN INCHES.
2. SEE CHART FOR DIMENSIONAL TOLERANCE.

THIS OR FACSIMILE THEREOF IS THE EXCLUSIVE PROPERTY OF PHOENIX AND MAY NOT BE REPRODUCED WITHOUT THE EXPRESSED WRITTEN CONSENT OF PHOENIX. SOME OR ALL OF THE ITEMS DEPICTED ON THIS DRAWING MAY BE COVERED BY CURRENT PATENTS OR PATENTS APPLIED FOR BY PHOENIX.

REV	DATE	DESCRIPTION	BY
2	10.11.10	Added Seal Ring Ledge Transition	DN
TOLERANCE		PITCH/TPI .167 / 6	TURNS 1-1/8
		MAT'L	PP
.X	±0.1	DRAWN BEZ	DATE 10.25.04
.XX	±0.02	SCALE	3 : 1
.XXX	±0.010	28 - 400 - 62 S	
			REV 2

SHALLOW SKIRTED CLOSURES

28-400-62 S

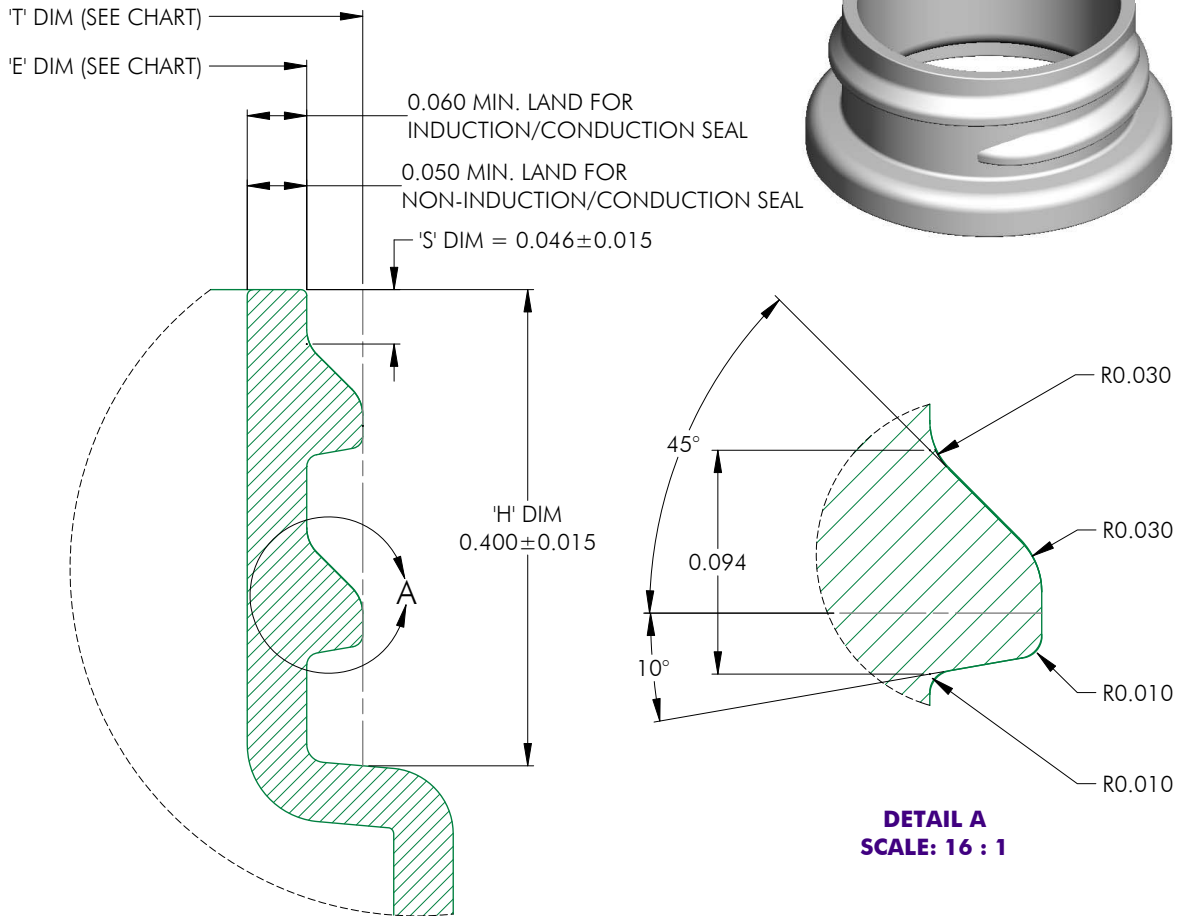

DETAIL A
SCALE: 16 : 1

MATERIAL	T (mean)	E (mean)	TOLERANCE
PP / PE	1.078	0.984	± 0.010
PET	1.080	0.986	± 0.008
GLASS	N/A	N/A	± N/A

NOTES: (UNLESS OTHERWISE SPECIFIED) 1. ALL DIMENSIONS ARE IN INCHES. 2. SEE CHART FOR DIMENSIONAL TOLERANCE. THIS OR FACSIMILE THEREOF IS THE EXCLUSIVE PROPERTY OF PHOENIX AND MAY NOT BE REPRODUCED WITHOUT THE EXPRESSED WRITTEN CONSENT OF PHOENIX. SOME OR ALL OF THE ITEMS DEPICTED ON THIS DRAWING MAY BE COVERED BY CURRENT PATENTS OR PATENTS APPLIED FOR BY PHOENIX.	0	11.15.04	Released	BZ					
	REV	DATE	DESCRIPTION	BY					
	TOLERANCE	PITCH/TPI	.167 / 6	TURNS	1-1/8	MAT'L	PER CHART		
	.X	±0.1	DRAWN	BEZ	DATE	11.15.04	SCALE	8 : 1	REV
	.XX	±0.02	28 - 400 - FINISH					0	
.XXX	±0.010								