

OASIS DISPENSING CLOSURES

# 24-DIS-CS13 U



## Specifications:

- DIAMETER** 24 mm
- THREAD PROFILE** 410
- NECK FINISH** 24-410
- CLOSURE TYPE** Flip-top dispensing
- CLOSURE TOP** Smooth
- CLOSURE SIDEWALL** Smooth
- MATERIAL** PP

## PACKAGING & FREIGHT INFORMATION

PACK TYPE	PCS/CTN	CTNS/PALT	PCS/PALT	CTN WT*	PALT WT*	FRT CLASS
Bulk	4,650	15	69,750	32 <sup>(1)</sup>	510 <sup>(1)</sup>	100 <sup>(1)</sup>
<b>CARTON DIMENSIONS: 24 x 16 x 15</b>			<b>PALLET DIMENSIONS: 48 x 40 x 50</b>			

(1) Unlined Closures (2) Lined Closures \*Approximate

### MARKETS

Hand Sanitizer, Liquid Soaps, Shampoos, Skin Care, Gels, Lotions, Syrup, Honey, Cleansers, Cleaning Liquids

### OPTIONS

Available in white, standard, and custom colors.

### CLOSURE BENEFITS

- 0.125" orifice
- Oasis Flip-Top Dispensing Closure
- Crab-claw linerless seal
- Smooth gloss finish
- Leak-free design
- Popular for hand sanitizers
- Popular for personal care items



PHXPKG.COM

P 630 420 4750 E greatpkg@phxpkg.com  
975 Meridian Lake Drive • Aurora, IL 60504

OASIS DISPENSING CLOSURES

# 24-DIS-CS13 U

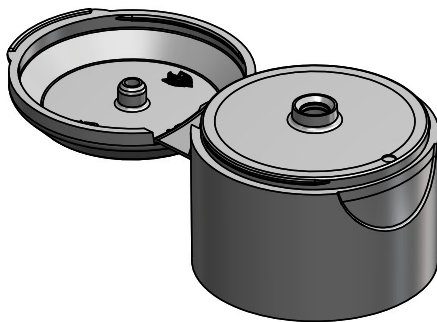
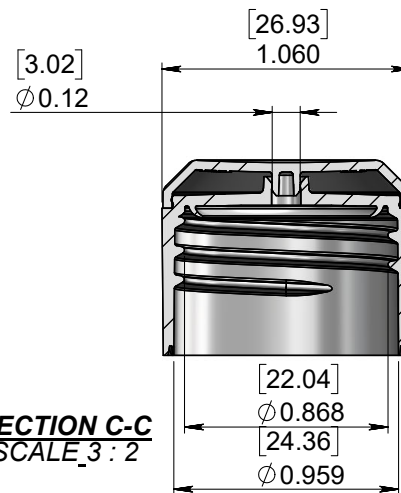
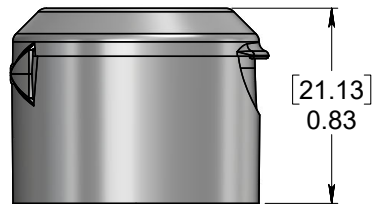
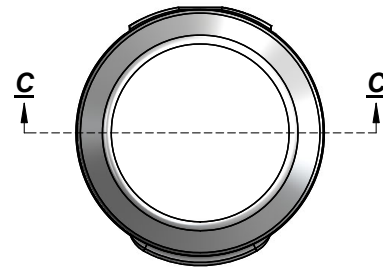

NOTES: (UNLESS OTHERWISE SPECIFIED)  
 1. ALL DIMENSIONS ARE IN INCHES.  
 2. SEE CHART FOR DIMENSIONAL TOLERANCE.

THIS OR FACSIMILE THEREOF IS THE EXCLUSIVE PROPERTY OF PHOENIX AND MAY NOT BE REPRODUCED WITHOUT THE EXPRESSED WRITTEN CONSENT OF PHOENIX. SOME OR ALL OF THE ITEMS DEPICTED ON THIS DRAWING MAY BE COVERED BY CURRENT PATENTS OR PATENTS APPLIED FOR BY PHOENIX.

D	04.20.20	Finalize Design, Add PCI Logo			TCS
REV	DATE	DESCRIPTION			BY
TOLERANCE	PITCH/TPI	.167 / 6	TURNS	1	MAT'L PP
.X	±0.1	DRAWN RAG	DATE 04.16.20	SCALE 1.5 : 1	REV
.XX	±0.02	024 - DIS - CS13 U			D
.XXX	±0.010				

OASIS DISPENSING CLOSURES

# 24-DIS-CS13 U

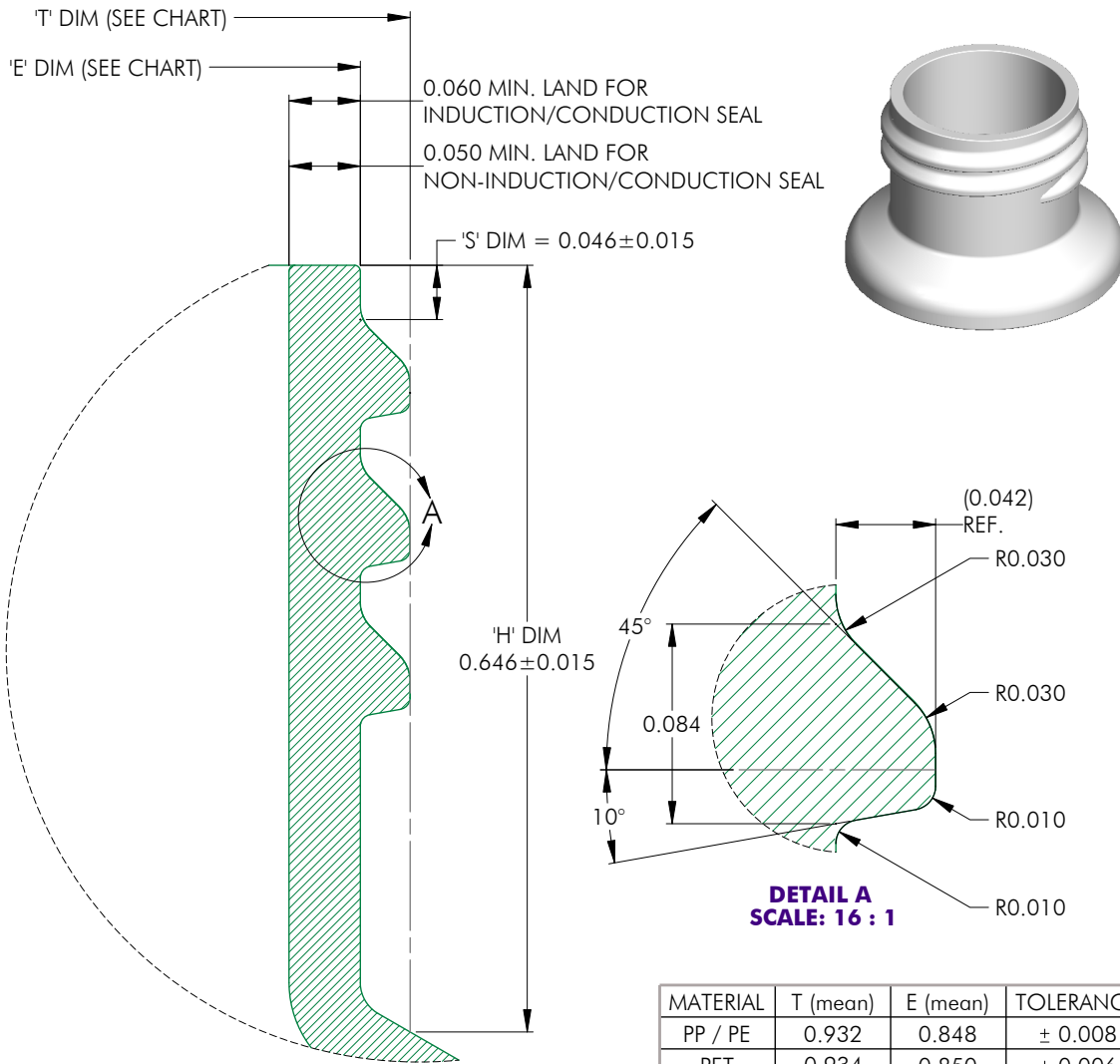

MATERIAL	T (mean)	E (mean)	TOLERANCE
PP / PE	0.932	0.848	± 0.008
PET	0.934	0.850	± 0.006
GLASS	N/A	N/A	± N/A

NOTES: (UNLESS OTHERWISE SPECIFIED)		0	10.19.04	Released	BZ
1. ALL DIMENSIONS ARE IN INCHES.		REV	DATE	DESCRIPTION	BY
2. SEE CHART FOR DIMENSIONAL TOLERANCE.		TOLERANCE	PITCH/TPI	.125 / 8	TURNS 2
THIS OR FACSIMILE THEREOF IS THE EXCLUSIVE PROPERTY OF PHOENIX AND MAY NOT BE REPRODUCED WITHOUT THE EXPRESSED WRITTEN CONSENT OF PHOENIX. SOME OR ALL OF THE ITEMS DEPICTED ON THIS DRAWING MAY BE COVERED BY CURRENT PATENTS OR PATENTS APPLIED FOR BY PHOENIX.		.X	±0.1	DRAWN BEZ	DATE 10.19.04
		.XX	±0.02	SCALE 8 : 1	REV
		.XXX	±0.010	24 - 410 - FINISH 0	