

MEDIUM & DEEP SKIRTED CLOSURES

24-410-62 S



Specifications:

DIAMETER 24 mm
THREAD PROFILE 410
NECK FINISH 24-410
CLOSURE TOP Stipple
CLOSURE SIDEWALL: Fine Ribbed
MATERIAL PP, PCR PP

PACKAGING & FREIGHT INFORMATION

PACK TYPE	PCS/CTN	CTNS/PALT	PCS/PALT	CTN WT*	PALT WT*	FRT CLASS
Bulk	5,500	15	82,500	29 ⁽¹⁾	441 ⁽¹⁾	100 ⁽¹⁾
Bulk	5,500	15	82,500	31 ⁽²⁾	471 ⁽²⁾	100 ⁽²⁾
CARTON DIMENSIONS: 24 x 16 x 15			PALLET DIMENSIONS: 48 x 40 x 50			

(1) Unlined Closures (2) Lined Closures *Approximate

MARKETS

Automotive, Industrial, and Medical Products, Household Chemicals, Personal Care & Cosmetics, Dressings & Sauces, Food, Food Service and Pharmaceuticals.

CLOSURE BENEFITS

- A great general-purpose closure
- Fine-ribbed sides are easier to grip
- Our most popular closure style

OPTIONS

Available in white, standard colors, and custom colors.

Can be lined with a wide variety of liner systems.

Optional 25–30% food-contact PCR PP material available.

MEDIUM & DEEP SKIRTED CLOSURES

24-410-62 S

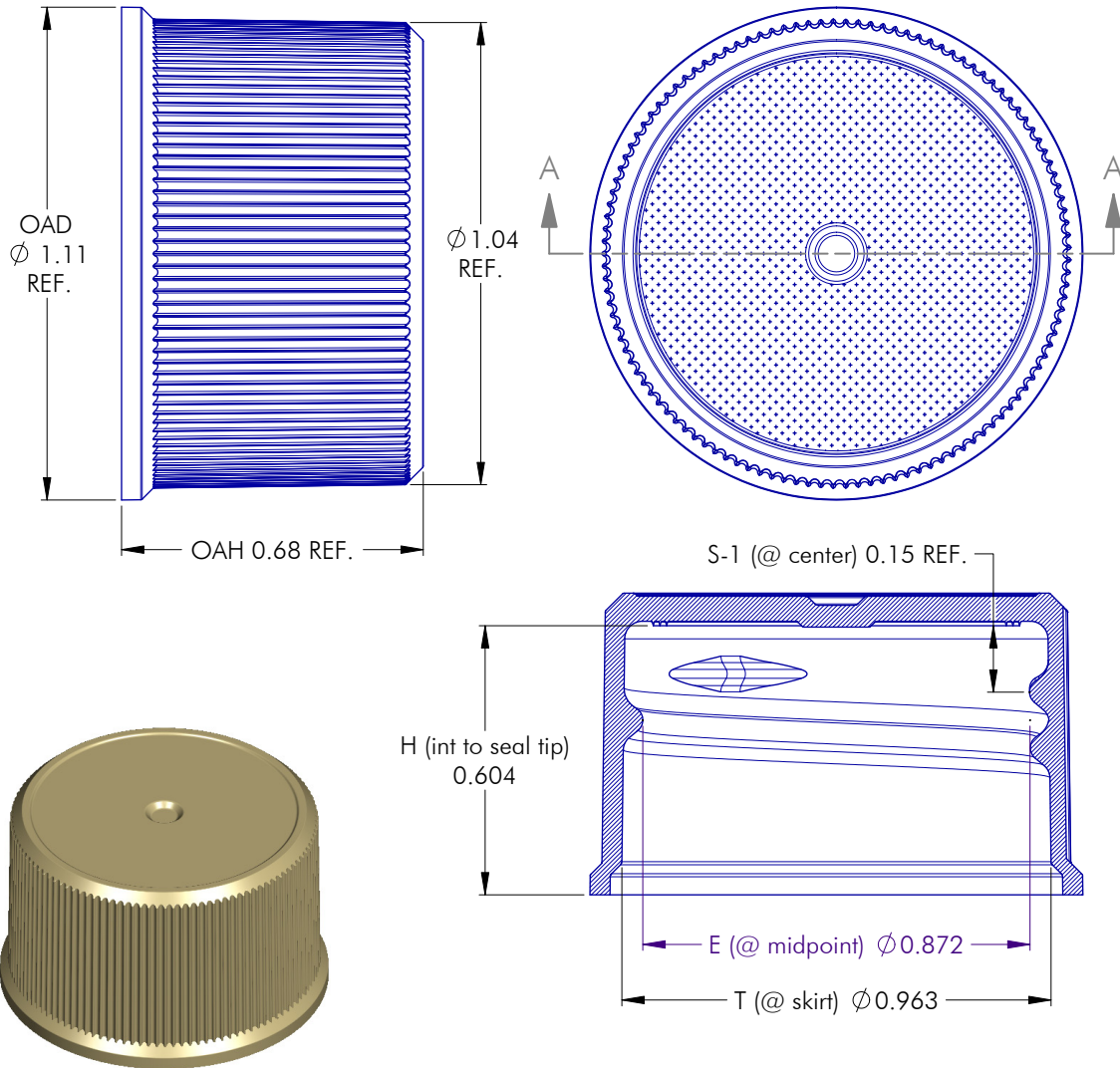

NOTES: (UNLESS OTHERWISE SPECIFIED)

1. ALL DIMENSIONS ARE IN INCHES.
2. SEE CHART FOR DIMENSIONAL TOLERANCE.

THIS OR FACSIMILE THEREOF IS THE EXCLUSIVE PROPERTY OF PHOENIX AND MAY NOT BE REPRODUCED WITHOUT THE EXPRESSED WRITTEN CONSENT OF PHOENIX. SOME OR ALL OF THE ITEMS DEPICTED ON THIS DRAWING MAY BE COVERED BY CURRENT PATENTS OR PATENTS APPLIED FOR BY PHOENIX.

REV	DATE	DESCRIPTION	BY
5	09.26.11	Modified Interior Wall	DN
TOLERANCE		PITCH/TPI .125 / 8	TURNS 1-1/8
		MAT'L	PP
.X	±0.1	DRAWN BEZ	DATE 07.11.04
.XX	±0.02	SCALE	3 : 1
.XXX	±0.010	24 - 410 - 62 S	
			5

MEDIUM & DEEP SKIRTED CLOSURES

24-410-62 S

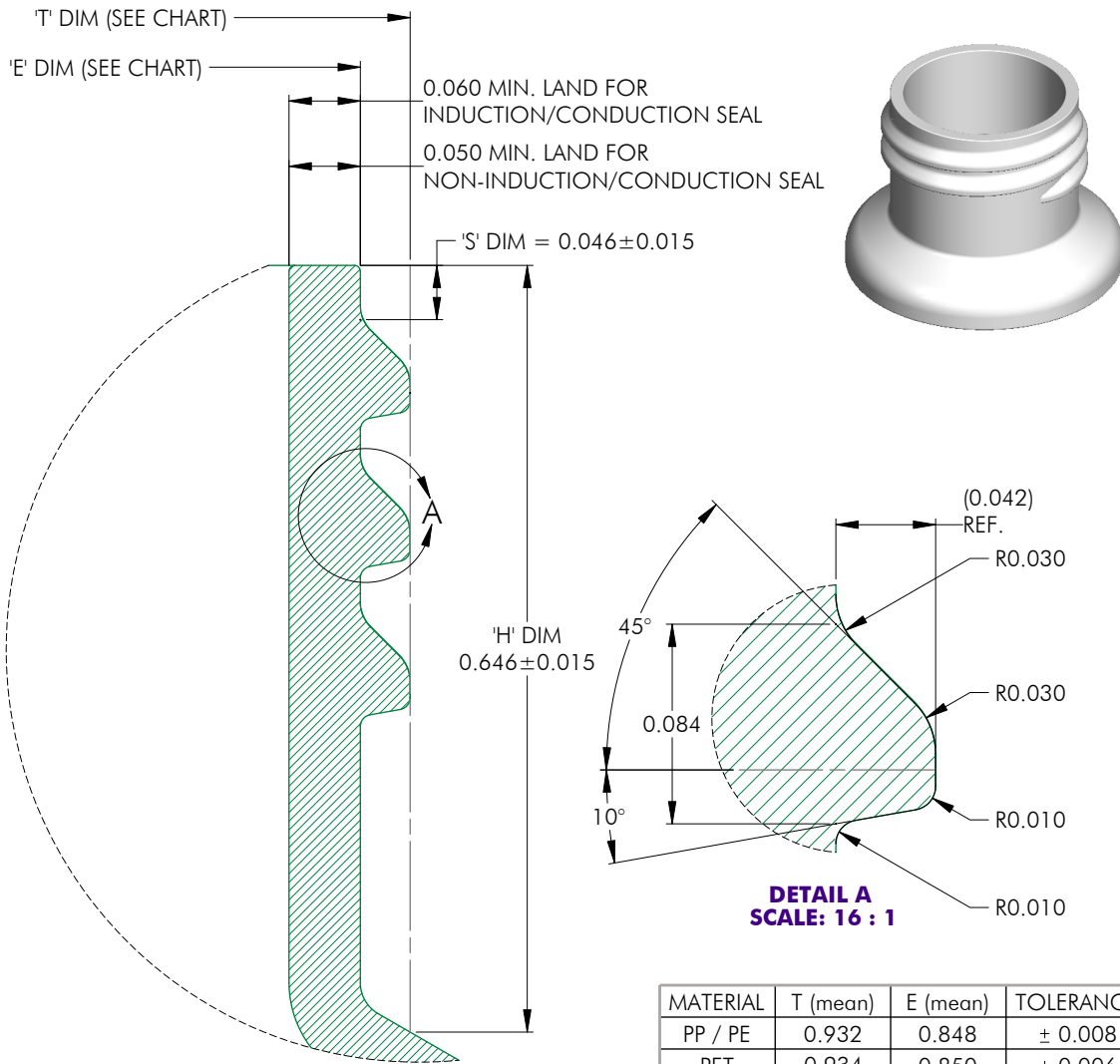

MATERIAL	T (mean)	E (mean)	TOLERANCE
PP / PE	0.932	0.848	± 0.008
PET	0.934	0.850	± 0.006
GLASS	N/A	N/A	± N/A

NOTES: (UNLESS OTHERWISE SPECIFIED)		0		10.19.04		Released		BZ	
1. ALL DIMENSIONS ARE IN INCHES.		REV	DATE	DESCRIPTION				BY	
2. SEE CHART FOR DIMENSIONAL TOLERANCE.									
THIS OR FACSIMILE THEREOF IS THE EXCLUSIVE PROPERTY OF PHOENIX AND MAY NOT BE REPRODUCED WITHOUT THE EXPRESSED WRITTEN CONSENT OF PHOENIX. SOME OR ALL OF THE ITEMS DEPICTED ON THIS DRAWING MAY BE COVERED BY CURRENT PATENTS OR PATENTS APPLIED FOR BY PHOENIX.		TOLERANCE	PITCH/TPI	.125 / 8	TURNS	2	MAT'L	PER CHART	
		.X	±0.1	DRAWN	BEZ	DATE	10.19.04	SCALE	8 : 1
		.XX	±0.02					REV	
		.XXX	±0.010						0
		24 - 410 - FINISH							