

MEDIUM & DEEP SKIRTED CLOSURES

120-DCT-76 S



Specifications:

DIAMETER 120 mm
THREAD PROFILE DCT
NECK FINISH 120-DCT
CLOSURE TOP Smooth
CLOSURE SIDEWALL: Broad Ribbed
MATERIAL PP, PCR PP

PACKAGING & FREIGHT INFORMATION

PACK TYPE	PCS/CTN	CTNS/PALT	PCS/PALT	CTN WT*	PALT WT*	FRT CLASS
Stacked	304	15	4,560	23 ⁽¹⁾	340 ⁽¹⁾	125 ⁽¹⁾
Stacked	304	15	4,560	25 ⁽²⁾	373 ⁽²⁾	125 ⁽²⁾
CARTON DIMENSIONS: 24 x 16 x 15			PALLET DIMENSIONS: 48 x 40 x 50			

(1) Unlined Closures (2) Lined Closures *Approximate

MARKETS

Nutritional Powders, Nutraceuticals, Food, Beverage, Home Care, Ag-Chem/Industrial

OPTIONS

Available in white, standard, and custom colors. Can be lined with a wide variety of liner systems including SureSeal (foam), pressure sensitive and heat induction (foil) liners. Offset printing is available on this closure in up to four colors. Multiple PCR materials available with food-contact and non-food options up to 100% PCR content.

CLOSURE BENEFITS

- EcoStack® nested stacking for improved quality and increased pack count
- Broad-ribbed sides are easier to grip
- Popular for nutritional powders
- Stocked in white (colors available)

MEDIUM & DEEP SKIRTED CLOSURES

120-DCT-76 S

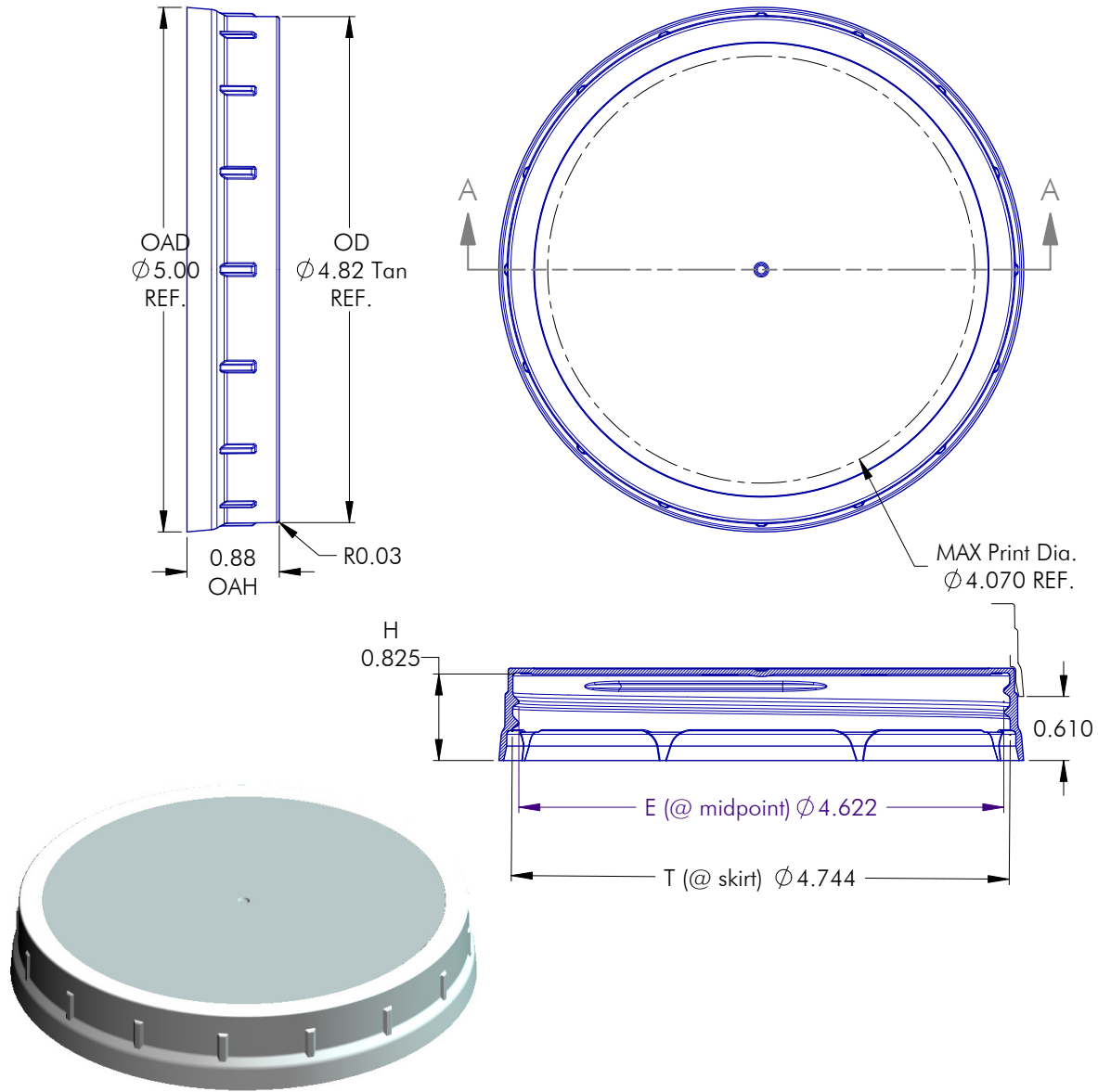

NOTES: (UNLESS OTHERWISE SPECIFIED) 1. ALL DIMENSIONS ARE IN INCHES. 2. SEE CHART FOR DIMENSIONAL TOLERANCE.		5	07.17.19	Eliminate "Phoenix" Engraving	TS
REV	DATE	DESCRIPTION			BY
TOLERANCE	PITCH/TPI	.200 / 5	TURNS	1-1/2	MAT'L PP
.X	±0.1	DRAWN TCS	DATE 09.06.18	SCALE 3/4 : 1	REV
.XX	±0.02	120 - DCT - 76 S			5
.XXX	±0.010				

MEDIUM & DEEP SKIRTED CLOSURES

120-DCT-76 S

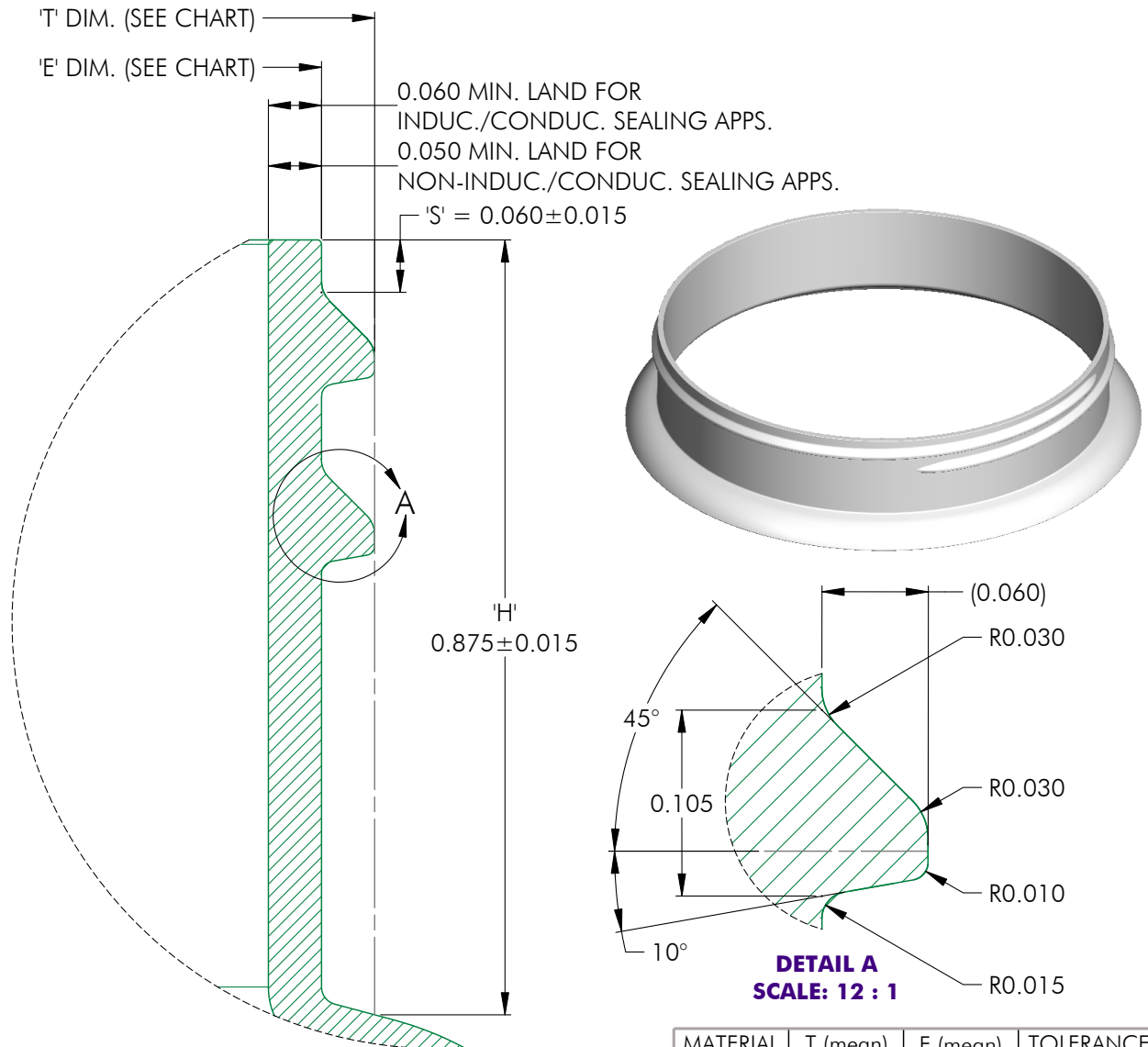

MATERIAL	T (mean)	E (mean)	TOLERANCE
PP / PE	4.707	4.587	± 0.018
PET	4.710	4.590	± 0.015
GLASS	N/A	N/A	± N/A

NOTES: (UNLESS OTHERWISE SPECIFIED) 1. ALL DIMENSIONS ARE IN INCHES. 2. SEE CHART FOR DIMENSIONAL TOLERANCE. THIS OR FACSIMILE THEREOF IS THE EXCLUSIVE PROPERTY OF PHOENIX AND MAY NOT BE REPRODUCED WITHOUT THE EXPRESSED WRITTEN CONSENT OF PHOENIX. SOME OR ALL OF THE ITEMS DEPICTED ON THIS DRAWING MAY BE COVERED BY CURRENT PATENTS OR PATENTS APPLIED FOR BY PHOENIX.	0	04.10.15	Released	DN					
	REV	DATE	DESCRIPTION	BY					
	TOLERANCE	PITCH/TPI	.200 / 5	TURNS	1-1/8	MATL	SEE CHART		
	.X	±0.1	DRAWN	DMN	DATE	04.10.15	SCALE	6 : 1	REV
	.XX	±0.02	120 - DCT - FINISH				0		
.XXX	±0.010								