

## MEDIUM &amp; DEEP SKIRTED CLOSURES

## 110-MUL-9740 S



## Specifications:

**DIAMETER** 110 mm  
**THREAD PROFILE** MUL  
**NECK FINISH** 110-MUL  
**CLOSURE TOP** Stipple  
**CLOSURE SIDEWALL** Fine Ribbed  
**MATERIAL** PP, PCR PP

## PACKAGING &amp; FREIGHT INFORMATION

PACK TYPE	PCS/CTN	CTNS/PALT	PCS/PALT	CTN WT*	PALT WT*	FRT CLASS
Stack	375	15	5,625	20 <sup>(1)</sup>	301 <sup>(1)</sup>	125 <sup>(1)</sup>
Stack	375	15	5,625	22.9 <sup>(2)</sup>	344 <sup>(2)</sup>	125 <sup>(2)</sup>
<b>CARTON DIMENSIONS:</b> 24 x 16 x 15			<b>PALLET DIMENSIONS:</b> 48 x 40 x 50			

(1) Unlined Closures (2) Lined Closures \*Approximate

## MARKETS

Agricultural, Automotive, Industrial, and Medical Products, Food, Food Service, Personal Care & Cosmetics, Pharmaceuticals, Peanut Butter & Nuts, Powdered Drinks, Dressings & Sauces.

## OPTIONS

Available in white, standard, and custom colors. Liners can be cut with tri-tab easy-open feature. Can be embossed/debossed with custom message. Offset printing is available in up to three colors. Multiple PCR materials available with food-contact and non-food options up to 100% PCR content.

## CLOSURE BENEFITS

- EcoStack® nested stacking for improved quality and increased pack count
- A great general-purpose closure
- Fine-ribbed sides are easier to grip
- Multi-lead threads allow for better consumer experience



**PHOENIX™**

PHXPKG.COM

P 630 420 4750 E greatpkg@phxpkg.com  
 975 Meridian Lake Drive • Aurora, IL 60504

## MEDIUM & DEEP SKIRTED CLOSURES

# 110-MUL-9740 S

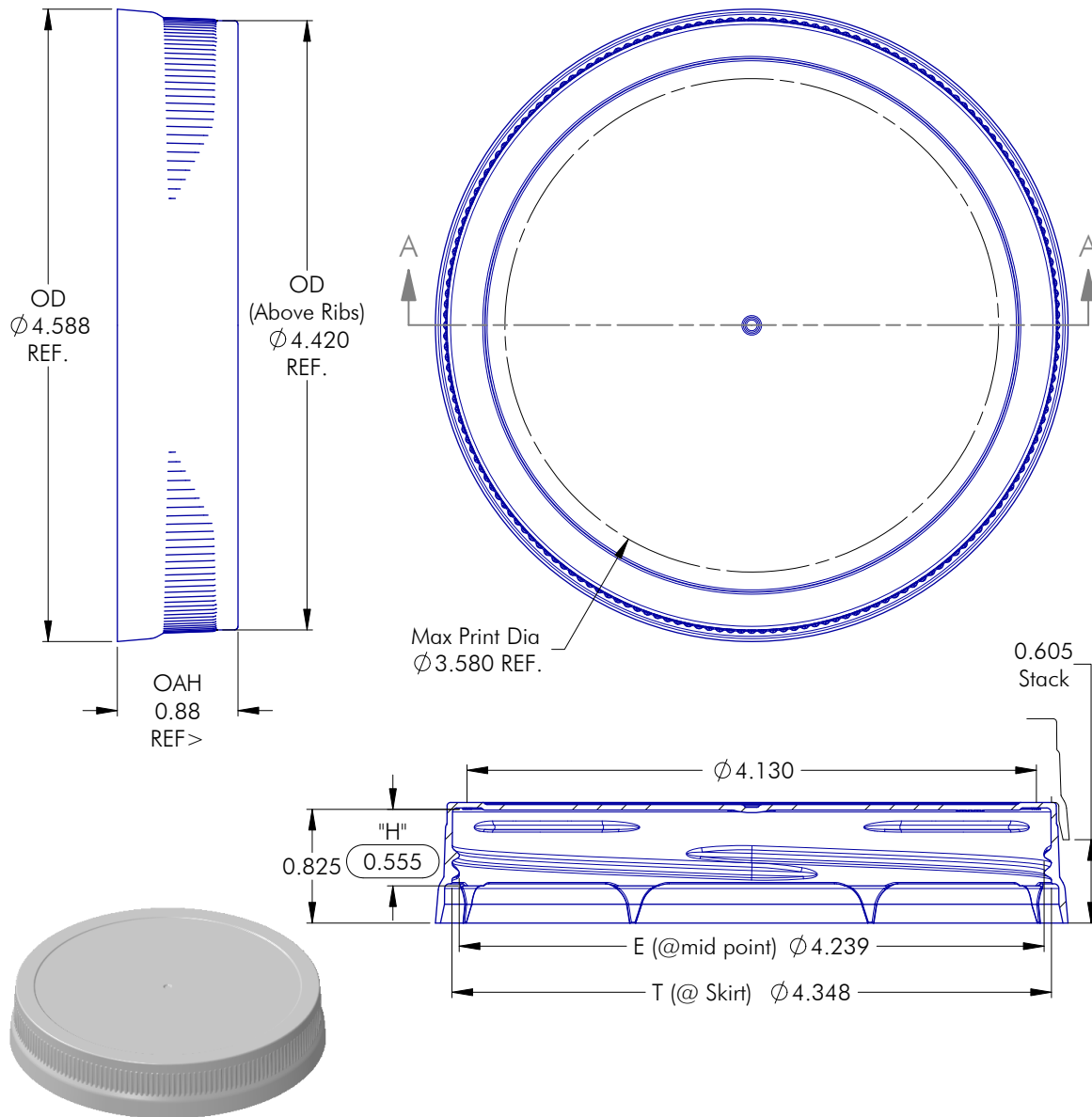

NOTES: (UNLESS OTHERWISE SPECIFIED) 1. ALL DIMENSIONS ARE IN INCHES. 2. SEE CHART FOR DIMENSIONAL TOLERANCE.	3	11.29.21	Reduce Stack dia. clearance by .007/S		TS				
	REV	DATE	DESCRIPTION		BY				
THIS OR FACSIMILE THEREOF IS THE EXCLUSIVE PROPERTY OF PHOENIX AND MAY NOT BE REPRODUCED WITHOUT THE EXPRESSED WRITTEN CONSENT OF PHOENIX. SOME OR ALL OF THE ITEMS DEPICTED ON THIS DRAWING MAY BE COVERED BY CURRENT PATENTS OR PATENTS APPLIED FOR BY PHOENIX.	TOLERANCE	PITCH/TPI	.500"/0	URNS	1/4 x 4	MAT'L	PP		
	.X	±0.1	DRAWN	TCS	DATE	02.08.21	SCALE	1 : 1	
	.XX	±0.02	110 - MUL - 9740 S					REV	3
	.XXX	±0.010							

## MEDIUM & DEEP SKIRTED CLOSURES

# 110-MUL-9740 S

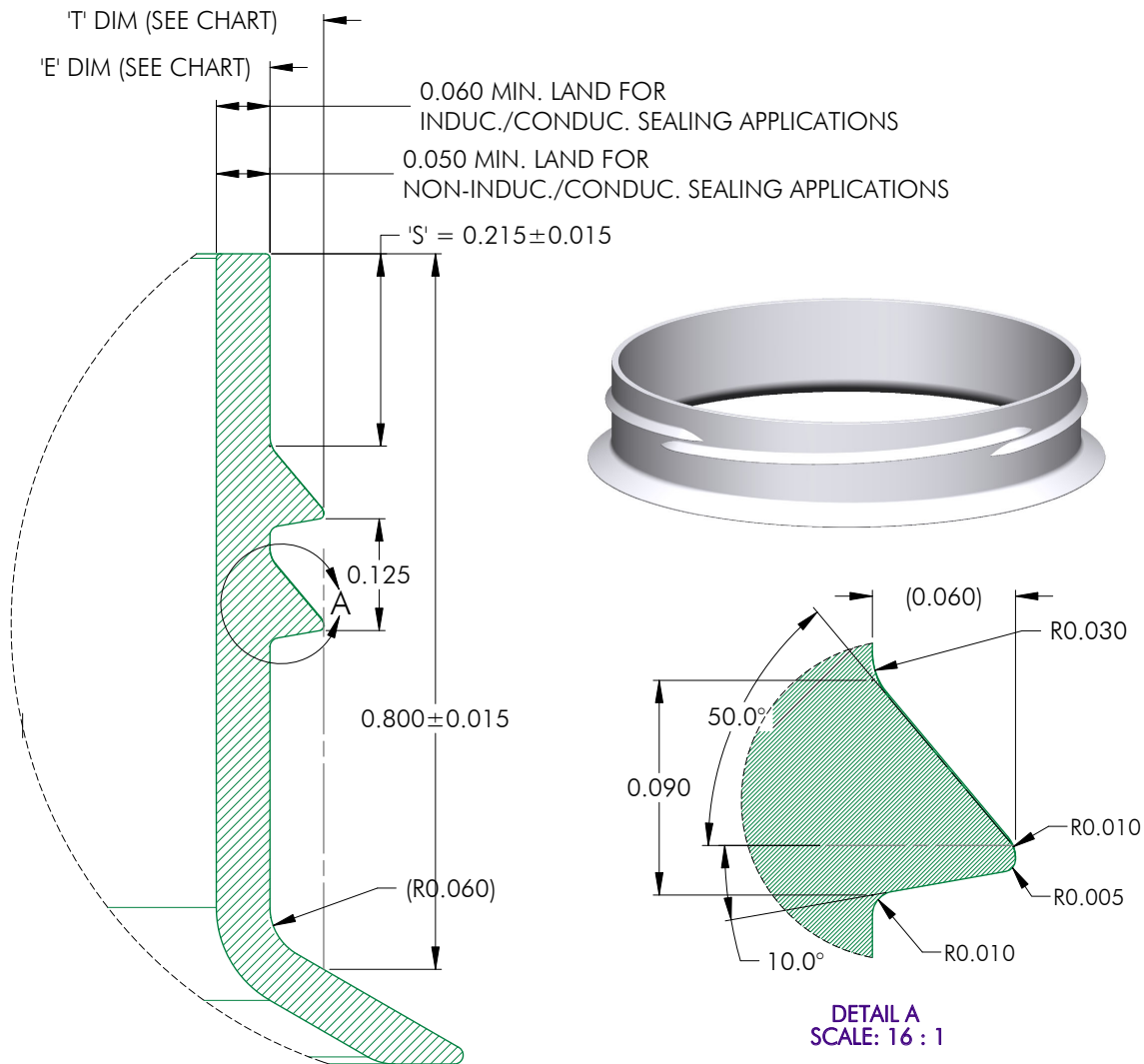

- NOTES: (UNLESS OTHERWISE SPECIFIED)
1. ALL DIMENSIONS ARE IN INCHES.
  2. SEE CHART FOR TOLERANCE ON ALL DIMENSIONS.
  3. 4 LEADS OF THREAD, EQ. SPACED. 90° FULL THREAD PER LEAD.
  4. USED WITH 110-MUL-9740 CLOSURE

MATERIAL	T (mean)	E (mean)	TOLERANCE
PP / PE	4.3135	4.1935	± 0.0175
PET	4.319	4.199	± 0.012
GLASS	N/A	N/A	± N/A

NOTES: (UNLESS OTHERWISE SPECIFIED)		0	03.06.23	ORIGINAL RELEASE	TCS			
1. ALL DIMENSIONS ARE IN INCHES. 2. SEE CHART FOR DIMENSIONAL TOLERANCE.		REV	DATE	DESCRIPTION	BY			
THIS OR FACSIMILE THEREOF IS THE EXCLUSIVE PROPERTY OF PHOENIX AND MAY NOT BE REPRODUCED WITHOUT THE EXPRESSED WRITTEN CONSENT OF PHOENIX. SOME OR ALL OF THE ITEMS DEPICTED ON THIS DRAWING MAY BE COVERED BY CURRENT PATENTS OR PATENTS APPLIED FOR BY PHOENIX.	TOLERANCE		PITCH/TPI	.5/8 / 0	URNS	NOTE 3	MAT'L	SEE CHART
	.X	±0.1	DRAWN	TCS	DATE	03.06.23	SCALE	8 : 1
	.XX	±0.02	110 - MUL - QUAD FINISH				REV	0
	.XXX	±0.010						