

110-400-9613 S



Specifications:

DIAMETER	110 mm
NECK FINISH	110-400
CLOSURE TOP	Stipple
CLOSURE SIDEWALL	Fine Ribbed
MATERIAL	PP, PCR PP

PACKAGING & FREIGHT INFORMATION

PACK TYPE	PCS/CTN	CTNS/PALT	PCS/PALT	CTN WT*	PALT WT*	FRT CLASS
Stacked	333	15	4,995	17 ⁽¹⁾	257 ⁽¹⁾	150 ⁽¹⁾
Stacked	333	15	4,995	20 ⁽²⁾	293 ⁽²⁾	125 ⁽²⁾
CARTON DIMENSIONS: 24 x 16 x 15			PALLET DIMENSIONS: 48 x 40 x 50			

(1) Unlined Closures (2) Lined Closures *Approximate

MARKETS

Agricultural, Automotive, Industrial, and Medical Products, Food, Food Service, Personal Care & Cosmetics, Pharmaceuticals, Peanut Butter & Nuts, Powdered Drinks, Dressings & Sauces

CLOSURE BENEFITS

- A great general-purpose closure
- Fine-ribbed sides are easy to grip
- Our most popular closure style
- Utilized for peanut butter

OPTIONS

Available in white, standard, and custom colors. Liners can be cut with a tri-tab easy-open feature. Can be embossed/debossed with custom message. Offset printing is available in up to four colors. Multiple PCR materials available with food-contact and non-food options up to 100% PCR.



PHOENIX™

PHXPKG.COM

P 630 420 4750 E greatpkg@phxpkg.com
975 Meridian Lake Drive • Aurora, IL 60504

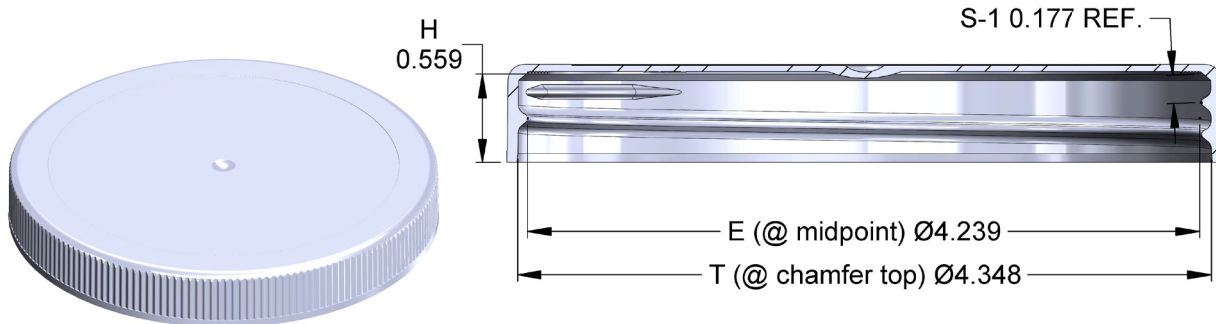
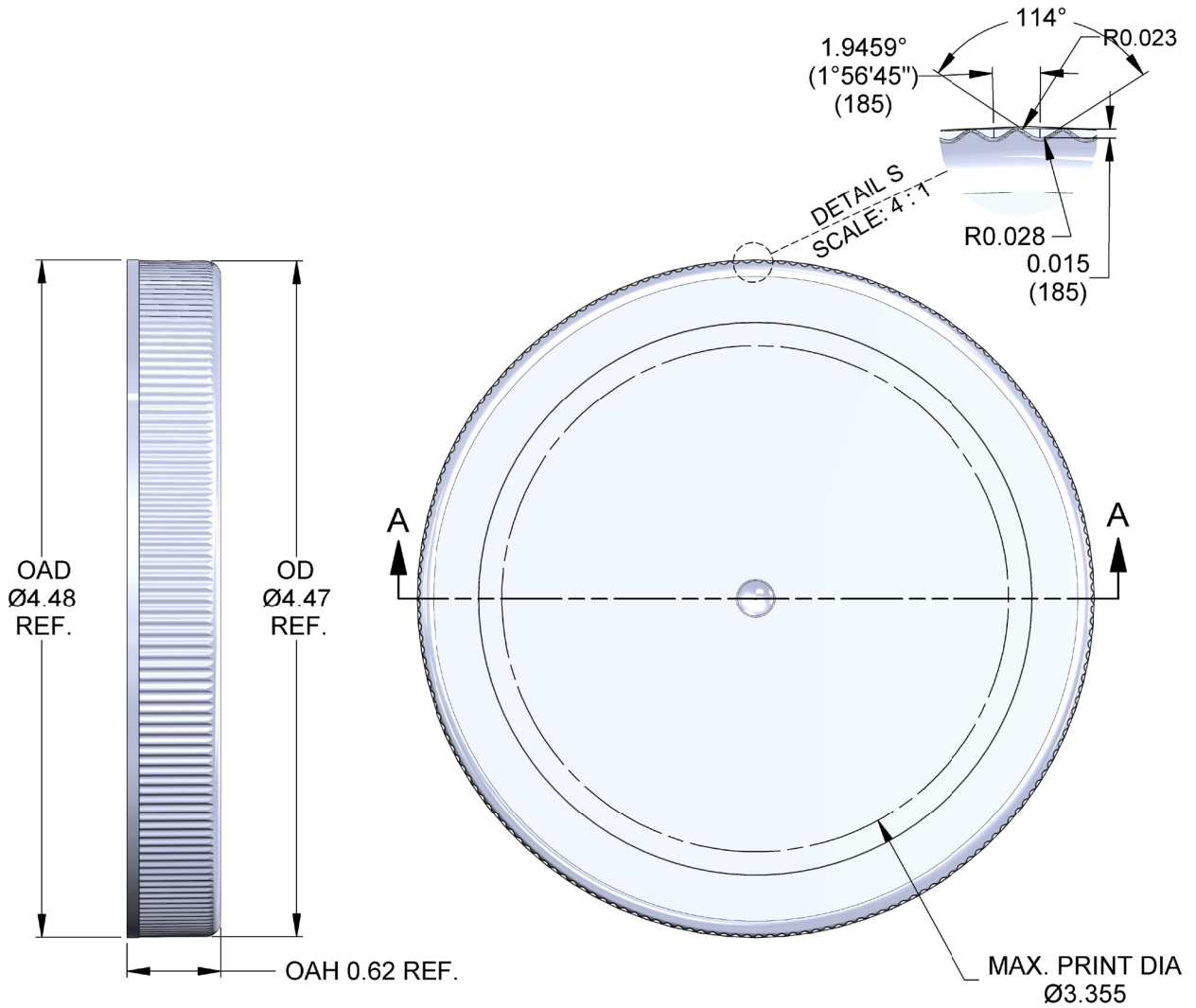

NOTES: (UNLESS OTHERWISE SPECIFIED) 1. ALL DIMENSIONS ARE IN INCHES. 2. SEE CHART FOR DIMENSIONAL TOLERANCE. THIS OR FACSIMILE THEREOF IS THE EXCLUSIVE PROPERTY OF PHOENIX AND MAY NOT BE REPRODUCED WITHOUT THE EXPRESSED WRITTEN CONSENT OF PHOENIX. SOME OR ALL OF THE ITEMS DEPICTED ON THIS DRAWING MAY BE COVERED BY CURRENT PATENTS OR PATENTS APPLIED FOR BY PHOENIX.	9	06.10.25	ADDED .003"/S TO TUMBLE BAND		CPP				
	REV	DATE	DESCRIPTION		BY				
	.X	±0.1	PITCH/TPI	.200 / 5	TURNS	1-1/4	MAT'L	PP	REV
	.XX	±0.02	DRAWN	DMN	DATE	06.29.09	SCALE	1 : 1	REV
.XXX	±0.010	110 - 400 - 9613S				9			

SHALLOW SKIRTED CLOSURES

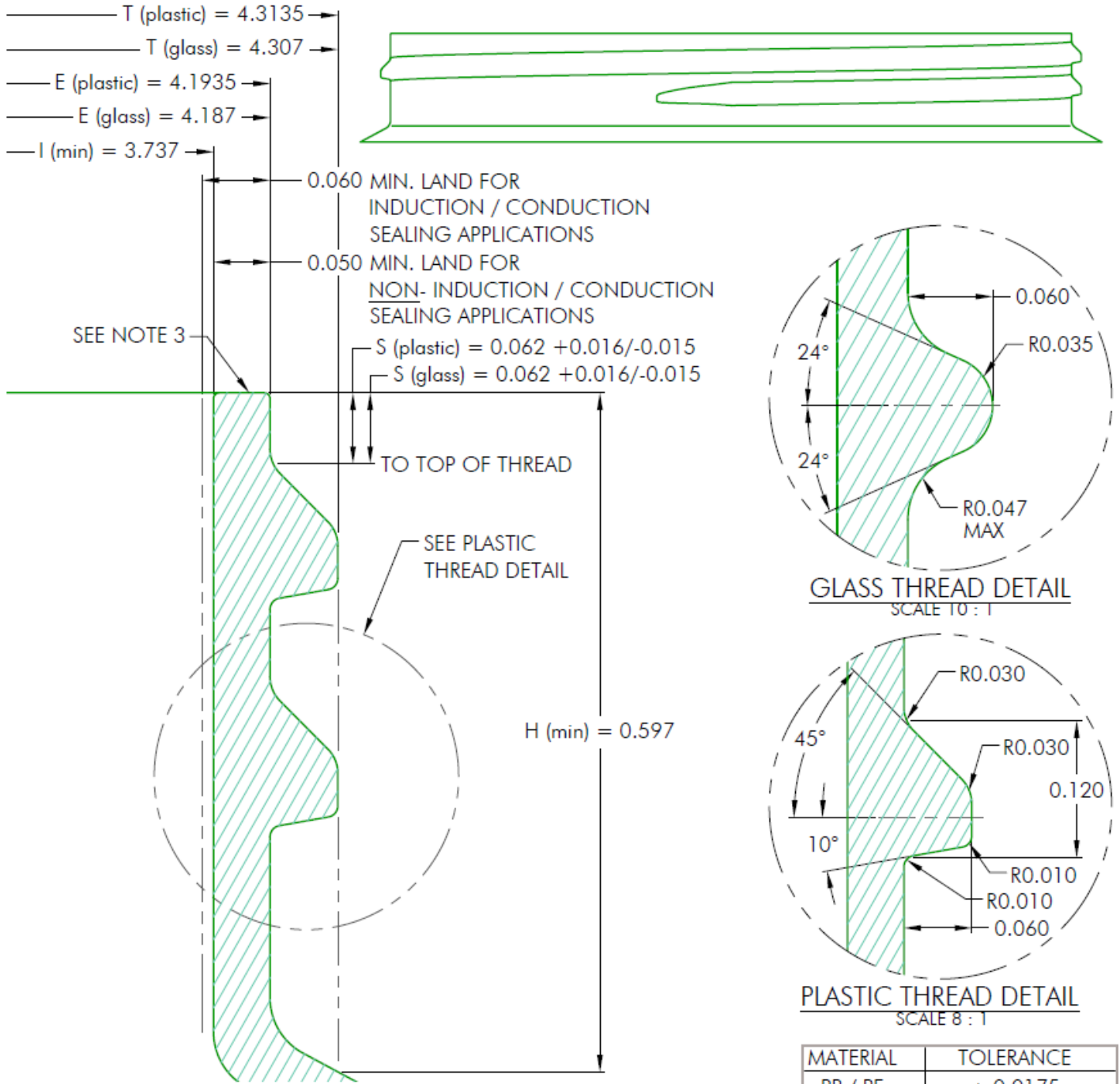

MATERIAL	TOLERANCE
PP / PE	± 0.0175
PET	± 0.012
GLASS	± 0.024

NOTES: (UNLESS OTHERWISE SPECIFIED)
 1. ALL DIMENSIONS ARE IN INCHES.
 2. SEE CHART FOR DIMENSIONAL TOLERANCE.

0	11.17.97	Released	BZ
REV	DATE	DESCRIPTION	BY
TOLERANCE		PITCH/TPI .200 / 5	TURNS 1-1/4
MATERIAL Per Chart		DATE 11.17.97	SCALE 8 : 1
.X	±0.1	DRAWN BEZ	REV
.XX	±0.02	110 - 400 - FINISH	
.XXX	±0.010		



PHXPKG.COM
 P 630 420 4750 E greatpkg@phxpkg.com
 975 Meridian Lake Drive • Aurora, IL 60504