

SMOOTH TOPS & SIDES

100-400-85 S



Specifications:

DIAMETER 100 mm
THREAD PROFILE 400
NECK FINISH 100-400
CLOSURE TOP Smooth
CLOSURE SIDEWALL Smooth
MATERIAL PP, PCR PP

PACKAGING & FREIGHT INFORMATION

PACK TYPE	PCS/CTN	CTNS/PALT	PCS/PALT	CTN WT*	PALT WT*	FRT CLASS
Stacked	500	15	7,500	16 ⁽¹⁾	282 ⁽¹⁾	175 ⁽¹⁾
Stacked	500	15	7,500	19 ⁽²⁾	322 ⁽²⁾	175 ⁽²⁾
CARTON DIMENSIONS: 24 x 16 x 15		PALLET DIMENSIONS: 48 x 40 x 50				

(1) Unlined Closures (2) Lined Closures *Approximate

MARKETS

Nutraceuticals, Personal Care & Cosmetics, and Pharmaceuticals.

OPTIONS

Available in white, standard, and custom colors. Can be lined with a variety of liner systems including SureSeal (foam), pressure sensitive and heat induction (foil) liners. Liners can be cut with a tri-tab easy-open feature. Offset printing is available on this closure in up to four colors. Optional 25-30% food-contact safe PCR PP material available.

CLOSURE BENEFITS

- Smooth top and sides lend a “clean” look to the package
- Popular for vitamins and nutraceuticals
- Popular for cosmetics



PHOENIX™

PHXPKG.COM

P 630 420 4750 E greatpkg@phxpkg.com
 975 Meridian Lake Drive • Aurora, IL 60504

SMOOTH TOPS & SIDES

100-400-85 S

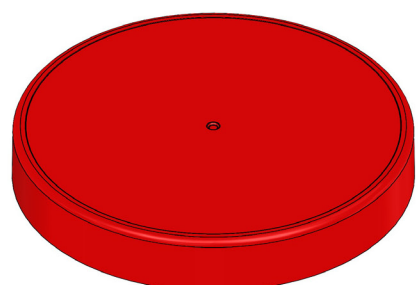
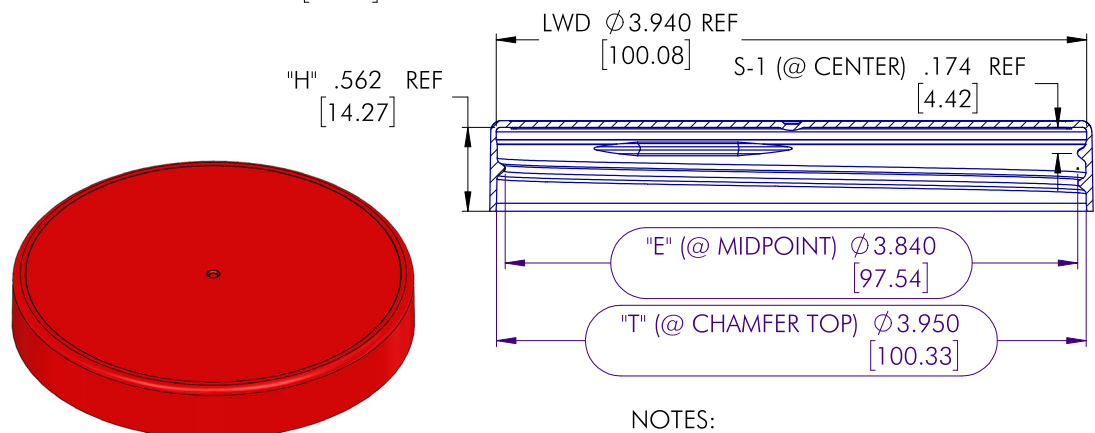
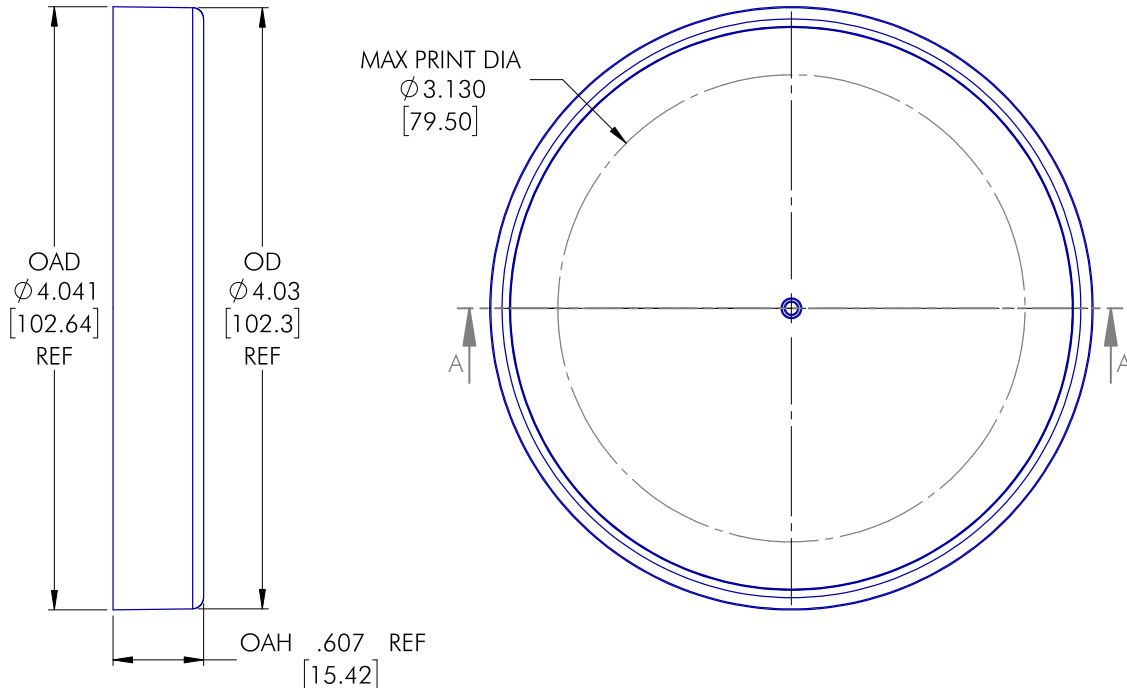

SCALE 2:3

- NOTES:
1. DIMENSIONS IN BRACKETS [] ARE MM
 2. WEIGHT: 12.13g \pm 10%
 3. GENERAL TOLERANCE: \pm .010 [.25]

PITCH/TPI .200 / 5	TYPE CS	MAT'L PP	0	10.11.22	PRODUCTION RELEASE	RJP
DRAWN RJP	DATE 10.11.22	SCALE 1 : 1	REV	DATE	DESCRIPTION	BY
THIS OR FACSIMILE THEREOF IS THE EXCLUSIVE PROPERTY OF PHOENIX AND MAY NOT BE REPRODUCED WITHOUT THE EXPRESSED WRITTEN CONSENT OF PHOENIX. SOME OR ALL OF THE ITEMS DEPICTED ON THIS DRAWING MAY BE COVERED BY CURRENT PATENTS OR PATENTS APPLIED FOR BY PHOENIX.					TITLE	REV
					100-400 CT V-SEAL	
100 - 400 - 85 S						

SMOOTH TOPS & SIDES

100-400-85 S

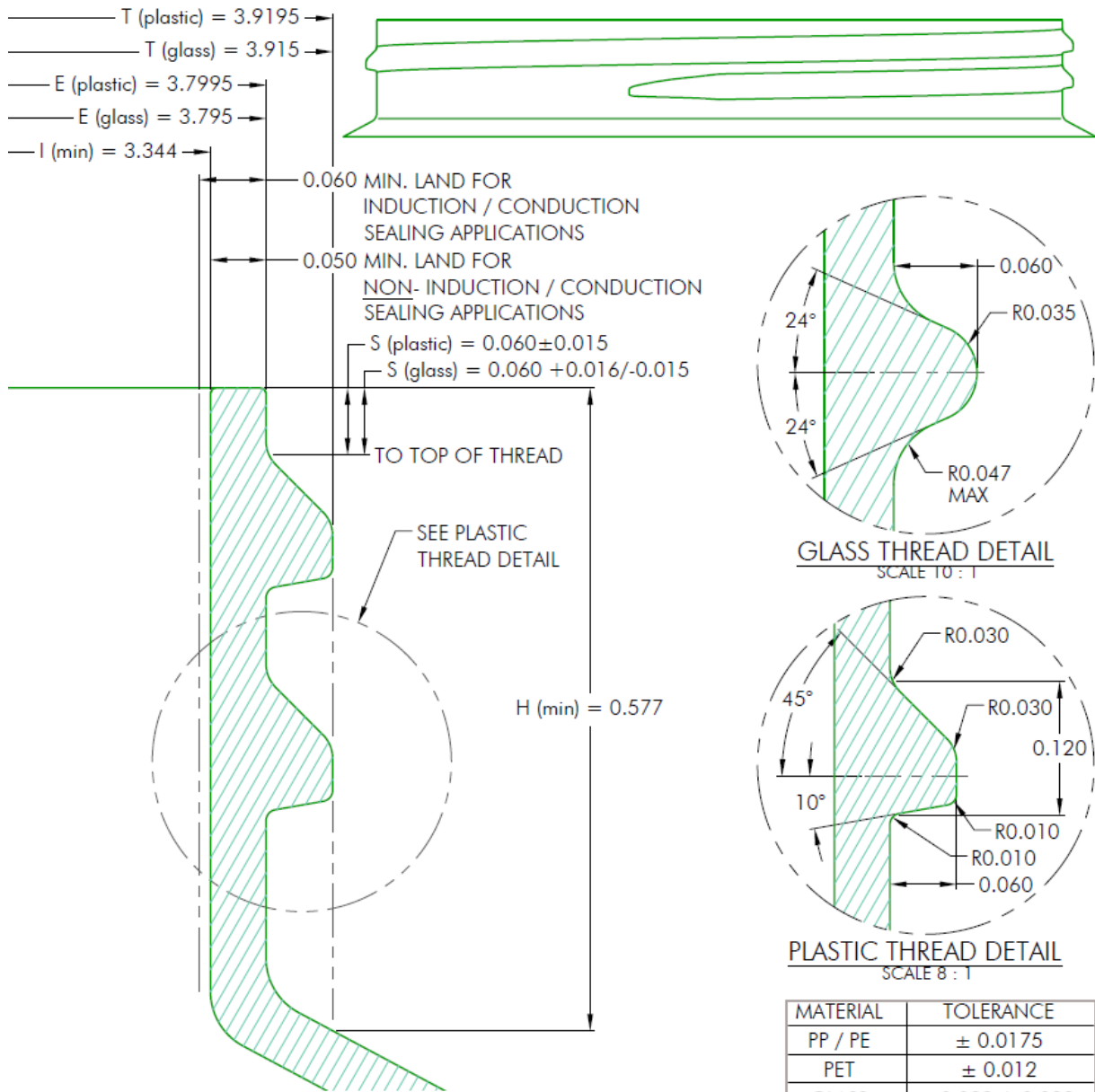

MATERIAL	TOLERANCE
PP / PE	± 0.0175
PET	± 0.012
GLASS	+0.022 / -0.023

NOTES: (UNLESS OTHERWISE SPECIFIED) 1. ALL DIMENSIONS ARE IN INCHES. 2. SEE CHART FOR DIMENSIONAL TOLERANCE.		0	05.23.03	Released	BZ					
THIS OR FACSIMILE THEREOF IS THE EXCLUSIVE PROPERTY OF PHOENIX AND MAY NOT BE REPRODUCED WITHOUT THE EXPRESSED WRITTEN CONSENT OF PHOENIX. SOME OR ALL OF THE ITEMS DEPICTED ON THIS DRAWING MAY BE COVERED BY CURRENT PATENTS OR PATENTS APPLIED FOR BY PHOENIX.		REV	DATE	DESCRIPTION	BY					
		TOLERANCE	PITCH/TPI	.200 / 5	TURNS	1-1/4	MAT'L	Per Chart		
		.X	±0.1	DRAWN	BEZ	DATE	05.23.03	SCALE	8 : 1	REV
		.XX	±0.02	100 - 400 - FINISH			0			
.XXX	±0.010									