

MESA NUTRA DISPENSING CLOSURES

# 45-NTR-GC S



## Specifications:

**DIAMETER** 45 mm  
**THREAD PROFILE** 400  
**NECK FINISH** 45-400  
**CLOSURE TOP** Flip-top  
**CLOSURE SIDEWALL** Smooth  
**MATERIAL** PP

### PACKAGING & FREIGHT INFORMATION

PACK TYPE	PCS/CTN	CTNS/PALT	PCS/PALT	CTN WT*	PALT WT*	FRT CLASS
Bulk	1,700	15	25,500	23 <sup>(1)</sup>	384 <sup>(1)</sup>	TBD <sup>(1)</sup>
Bulk	1,700	15	25,500	TBD <sup>(2)</sup>	TBD <sup>(2)</sup>	TBD <sup>(2)</sup>
<b>CARTON DIMENSIONS: 24 x 16 x 15</b>			<b>PALLET DIMENSIONS: 48 x 40 x 50</b>			

(1) Unlined Closures (2) Lined Closures \*Approximate

### MARKETS

Consumer Healthcare, Vitamins, Minerals, Supplements, Home Care, Food, Beverage

### OPTIONS

Available in white, standard colors and custom colors. Can be lined with a wide variety of liner systems. This closure can be embossed/debossed with your custom message.

### CLOSURE BENEFITS

- One-hand open and close makes dispensing easy
- MESA Nutra Flip-top dispensing closure
- Full lid remains open at 160°
- Full circle orifice
- Smooth design lends a clean look

MESA NUTRA DISPENSING CLOSURES

# 45-NTR-GC S

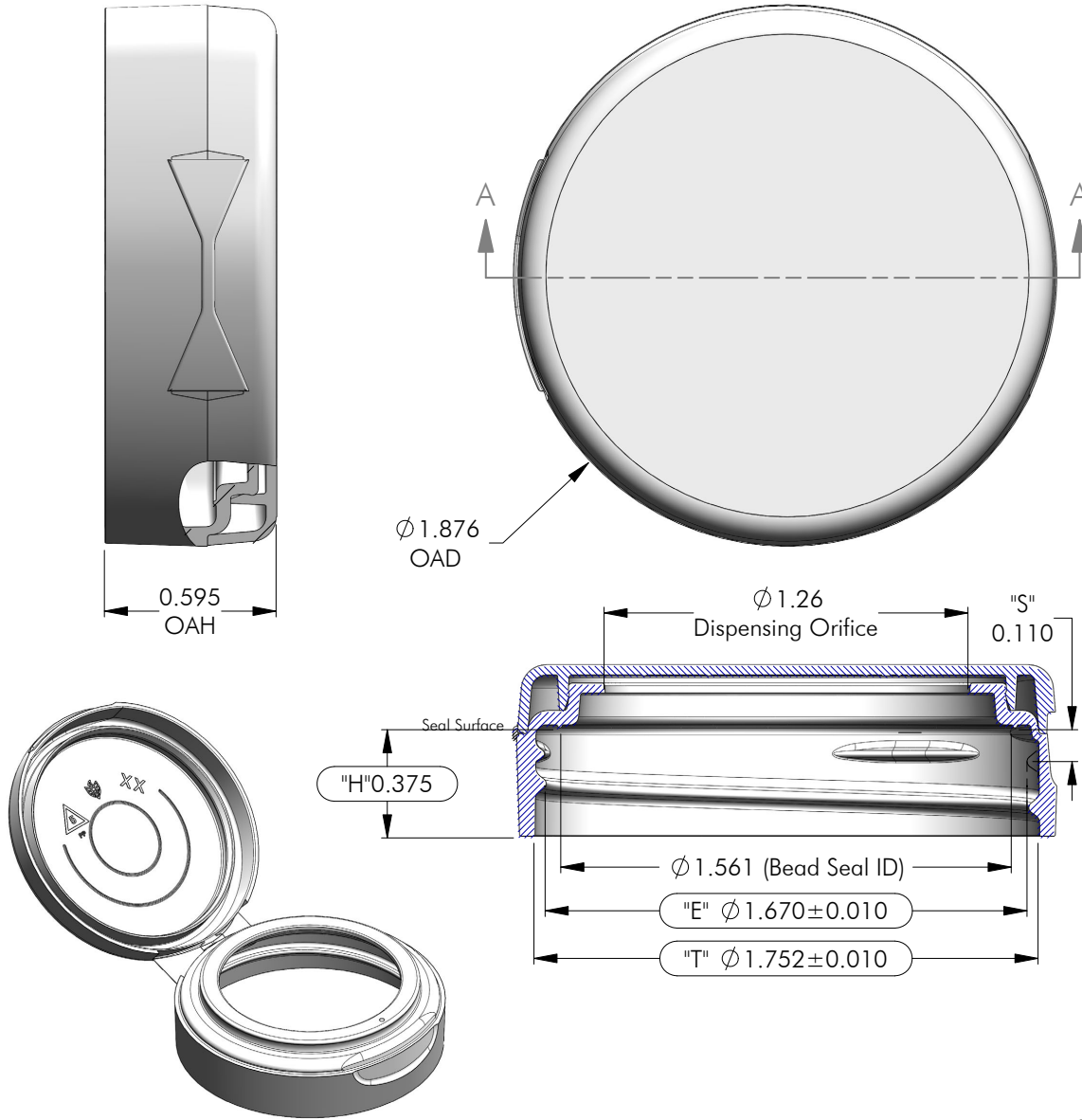

5.425

NOTES: (UNLESS OTHERWISE SPECIFIED) 1. ALL DIMENSIONS ARE IN INCHES. 2. SEE CHART FOR DIMENSIONAL TOLERANCE.		3	02.14.23	Add printing support rings to Lid	TCS			
REV	DATE	DESCRIPTION			BY			
THIS OR FACSIMILE THEREOF IS THE EXCLUSIVE PROPERTY OF PHOENIX AND MAY NOT BE REPRODUCED WITHOUT THE EXPRESSED WRITTEN CONSENT OF PHOENIX. SOME OR ALL OF THE ITEMS DEPICTED ON THIS DRAWING MAY BE COVERED BY CURRENT PATENTS OR PATENTS APPLIED FOR BY PHOENIX.		TOLERANCE	PITCH/TPI	.167 / 6	TURNS	7/8	MAT'L	PP
.X	±0.1	DRAWN	TCS	DATE	07.15.21	SCALE	2 : 1	REV
.XX	±0.02	045 - NTR - GC (S)			3			
.XXX	±0.010							

MESA NUTRA DISPENSING CLOSURES

# 45-NTR-GC S

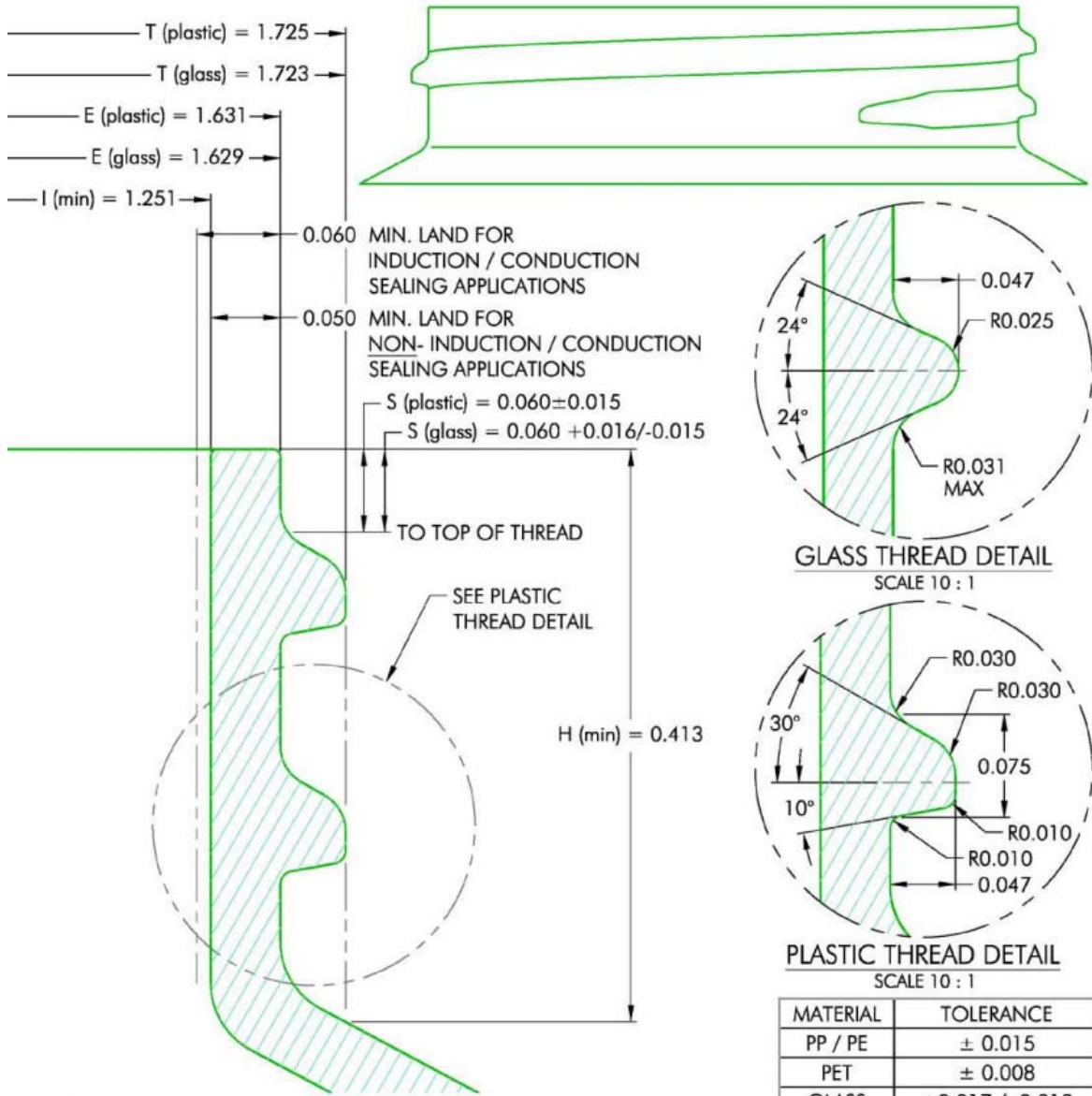

NOTES: (UNLESS OTHERWISE SPECIFIED)  
 1. ALL DIMENSIONS ARE IN INCHES.  
 2. SEE CHART FOR DIMENSIONAL TOLERANCE.

0	09.17.96	Released	BZ
REV	DATE	DESCRIPTION	BY
TOLERANCE PITCH/TPI .167 / 6 TURNS 1-1/8 MAT'L Per Chart .X $\pm 0.1$ DRAWN BEZ DATE 09.17.96 SCALE 10 : 1 REV .XX $\pm 0.02$ .XXX $\pm 0.010$			
<b>45 - 400 - FINISH</b>			0