

SCOOPS

# Z50-SCM-RDBK N



## Specifications:

**TYPE** Scoop  
**VOLUME** 5 oz  
**HANDLE** Medium  
**DESIGN** Round  
**MATERIAL** PP

### PACKAGING & FREIGHT INFORMATION

| PACK TYPE                              | PCS/CTN | CTNS/PALT | PCS/PALT                               | CTN WT* | PALT WT* | FRT CLASS |
|--|---------|-----------|--|---------|----------|-----------|
| Bulk                                   | 250     | 24        | 6,000                                  | 10      | 290      | 250       |
| <b>CARTON DIMENSIONS: 19 x 15 x 18</b> |         |           | <b>PALLET DIMENSIONS: 40 x 48 x 80</b> |         |          |           |

\*Approximate

### MARKETS

Nutritional Powders, Powdered Drinks, Baby Formulas, Household Chemical, Cleaning Products, Pet Products, Plant Food & Fertilizers

### OPTIONS

Available in natural, white, black, and colors. Custom logo engraving available.

### SCOOP BENEFITS

- Manufactured by HQC
- Customization options available
- Popular for nutritional powders



**PHOENIX™**

PHXPKG.COM

**P** 630 420 4750 **E** greatpkg@phxpkg.com  
 975 Meridian Lake Drive ▪ Aurora, IL 60504

SCOOPS

# Z50-SCM-RDBK N

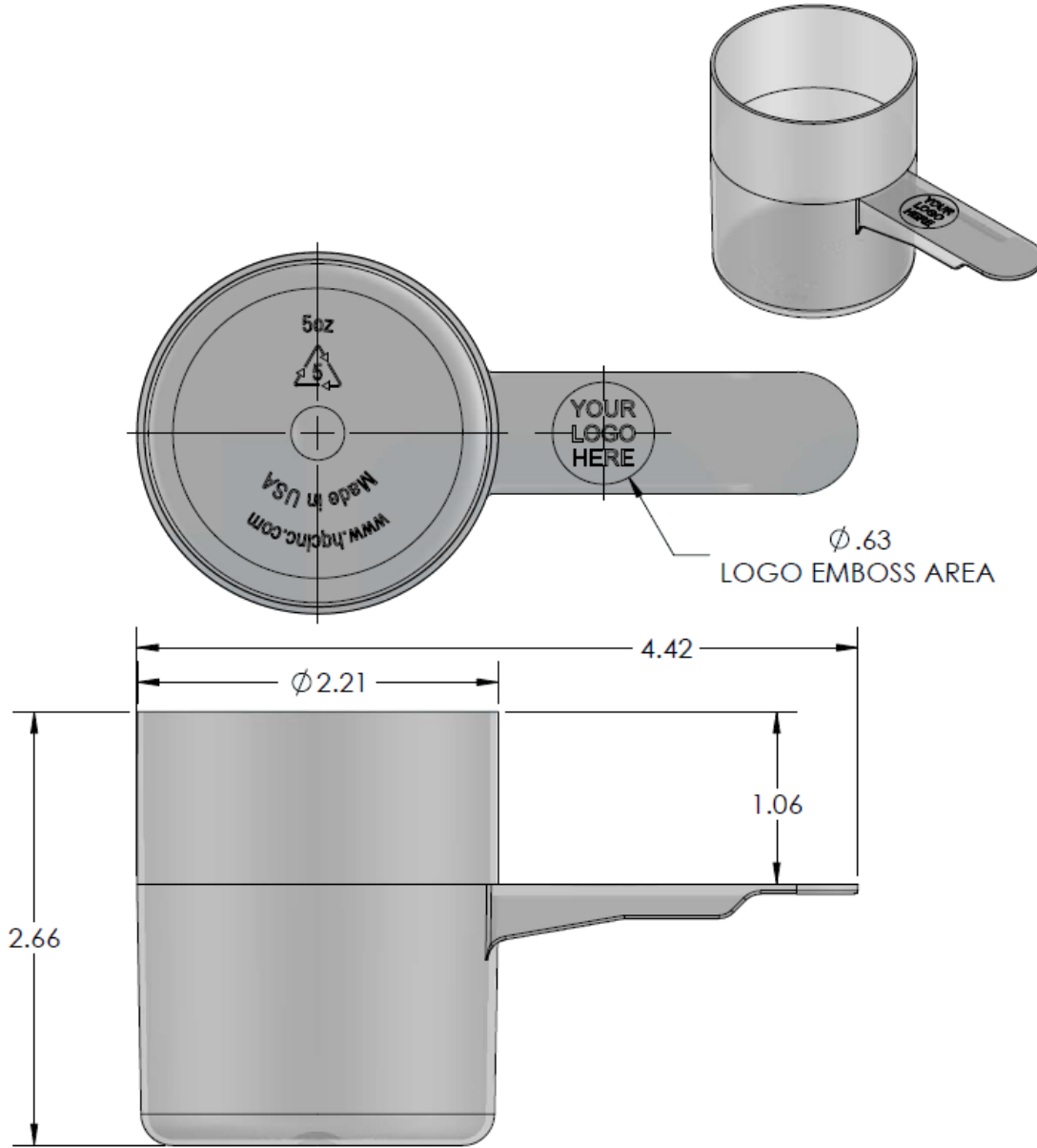

|   |           |                           |               |             |          |
|---|-----------|---------------------------|---------------|-------------|----------|
| NOTES: (UNLESS OTHERWISE SPECIFIED)<br>1. ALL DIMENSIONS ARE IN INCHES.<br>2. SEE CHART FOR DIMENSIONAL TOLERANCE.<br><br>THIS OR FACSIMILE THEREOF IS THE EXCLUSIVE PROPERTY OF PHOENIX AND MAY NOT BE REPRODUCED WITHOUT THE EXPRESSED WRITTEN CONSENT OF PHOENIX. SOME OR ALL OF THE ITEMS DEPICTED ON THIS DRAWING MAY BE COVERED BY CURRENT PATENTS OR PATENTS APPLIED FOR BY PHOENIX. | -         | 00.00.00                  | -             | --          |          |
|   | REV       | DATE                      | DESCRIPTION   | BY          |          |
|   | TOLERANCE | PITCH/TPI                 | NA / 0        | TURNS x     | MAT'L PP |
|   | .X ±0.1   | DRAWN HQC                 | DATE 01.05.15 | SCALE 0 : 1 | REV      |
|   | .XX ±0.02 | <b>Z50 - SCM - RDBK N</b> |               |             | <b>0</b> |
| .XXX ±0.010   |           |                           |               |             |          |



PHXPKG.COM

P 630 420 4750 E greatpkg@phxpkg.com  
 975 Meridian Lake Drive • Aurora, IL 60504