

MEDIUM & DEEP SKIRTED CLOSURES

56-445-4901 S



Specifications:

DIAMETER 56 mm
THREAD PROFILE 445
NECK FINISH 56-445
CLOSURE TOP Stipple
CLOSURE SIDEWALL: Broad Ribbed
MATERIAL PP

PACKAGING & FREIGHT INFORMATION

PACK TYPE	PCS/CTN	CTNS/PALT	PCS/PALT	CTN WT*	PALT WT*	FRT CLASS
Bulk	1,075	15	16,125	23 ⁽¹⁾	350 ⁽¹⁾	125 ⁽¹⁾
Bulk	1,200	15	18,000	29 ⁽²⁾	437 ⁽²⁾	100 ⁽²⁾
CARTON DIMENSIONS: 24 x 16 x 15			PALLET DIMENSIONS: 48 x 40 x 50			

(1) Unlined Closures (2) Lined Closures *Approximate

MARKETS

Food, Personal Care & Cosmetics.

CLOSURE BENEFITS

- Broad-ribbed sides are easier to grip

OPTIONS

Available in white, standard colors and custom colors. Can be lined with a wide variety of liner systems including SureSeal (foam), pressure sensitive and heat induction (foil) liners. Liners can be cut with a pull-tab easy-open feature. Can be embossed/debossed with custom message. Offset printing is available in up to three colors.



PHOENIX™

PHXPKG.COM

P 630 420 4750 E greatpkg@phxpkg.com
1899 High Grove Lane Naperville, IL 60540

MEDIUM & DEEP SKIRTED CLOSURES

56-445-4901 S

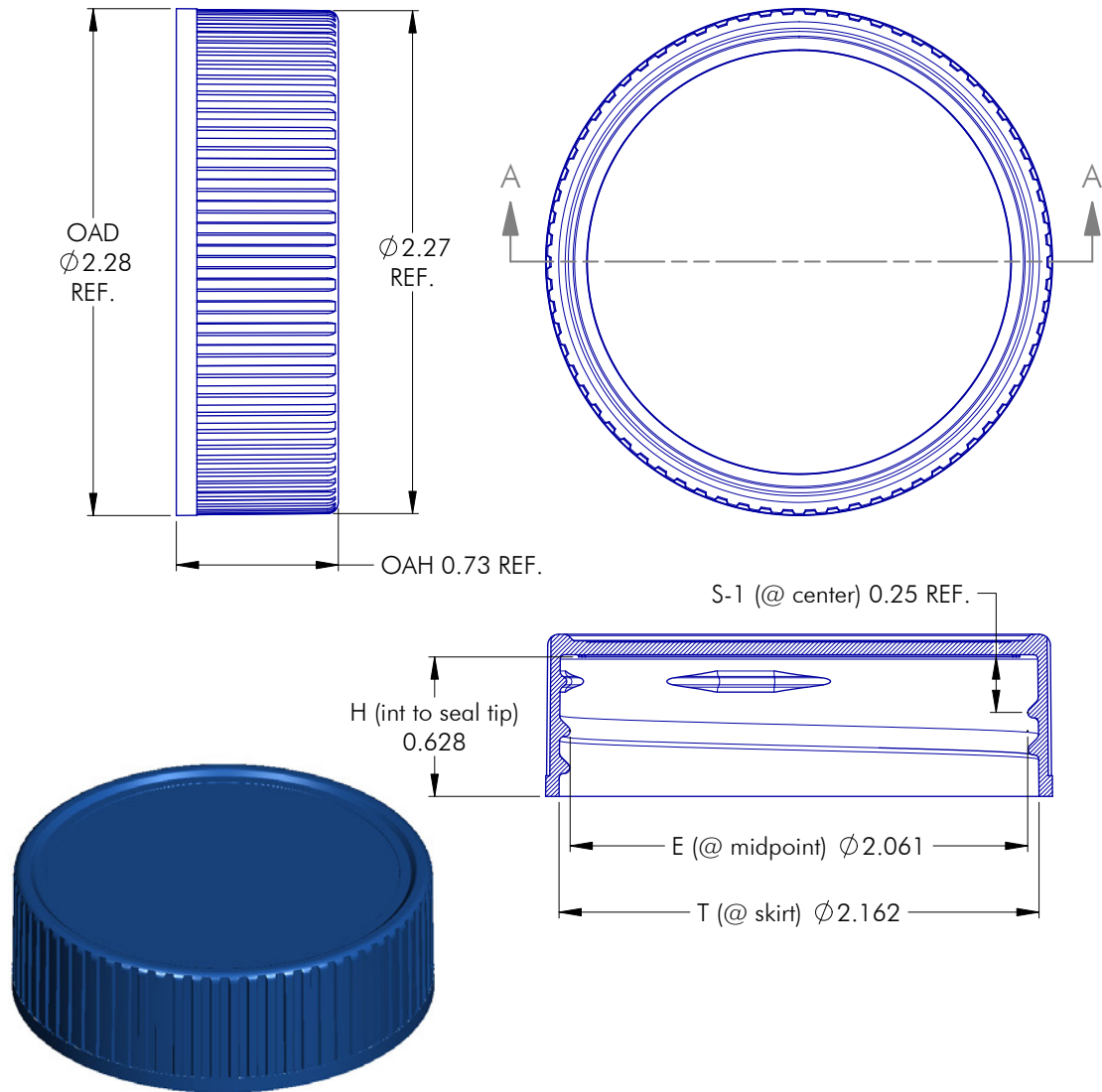

NOTES: (UNLESS OTHERWISE SPECIFIED)				1	05.22.02	Modify "S" Dimension	BZ					
1. ALL DIMENSIONS ARE IN INCHES.				REV	DATE	DESCRIPTION	BY					
2. SEE CHART FOR DIMENSIONAL TOLERANCE.				TOLERANCE	PITCH/TPI	.167 / 6	TURNS 1-1/2					
THIS OR FACSIMILE THEREOF IS THE EXCLUSIVE PROPERTY OF PHOENIX AND MAY NOT BE REPRODUCED WITHOUT THE EXPRESSED WRITTEN CONSENT OF PHOENIX. SOME OR ALL OF THE ITEMS DEPICTED ON THIS DRAWING MAY BE COVERED BY CURRENT PATENTS OR PATENTS APPLIED FOR BY PHOENIX.				.X	±0.1	MAT'L	PP					
				.XX	±0.02	DRAWN	BEZ	DATE	12.01.94	SCALE	3 : 2	REV
				.XXX	±0.010	56 - 445 - 4901 S				1		



PHOENIX™

PHXPKG.COM

P 630 420 4750 E greatpkg@phxpkg.com
1899 High Grove Lane Naperville, IL 60540

MEDIUM & DEEP SKIRTED CLOSURES

56-445-4901 S

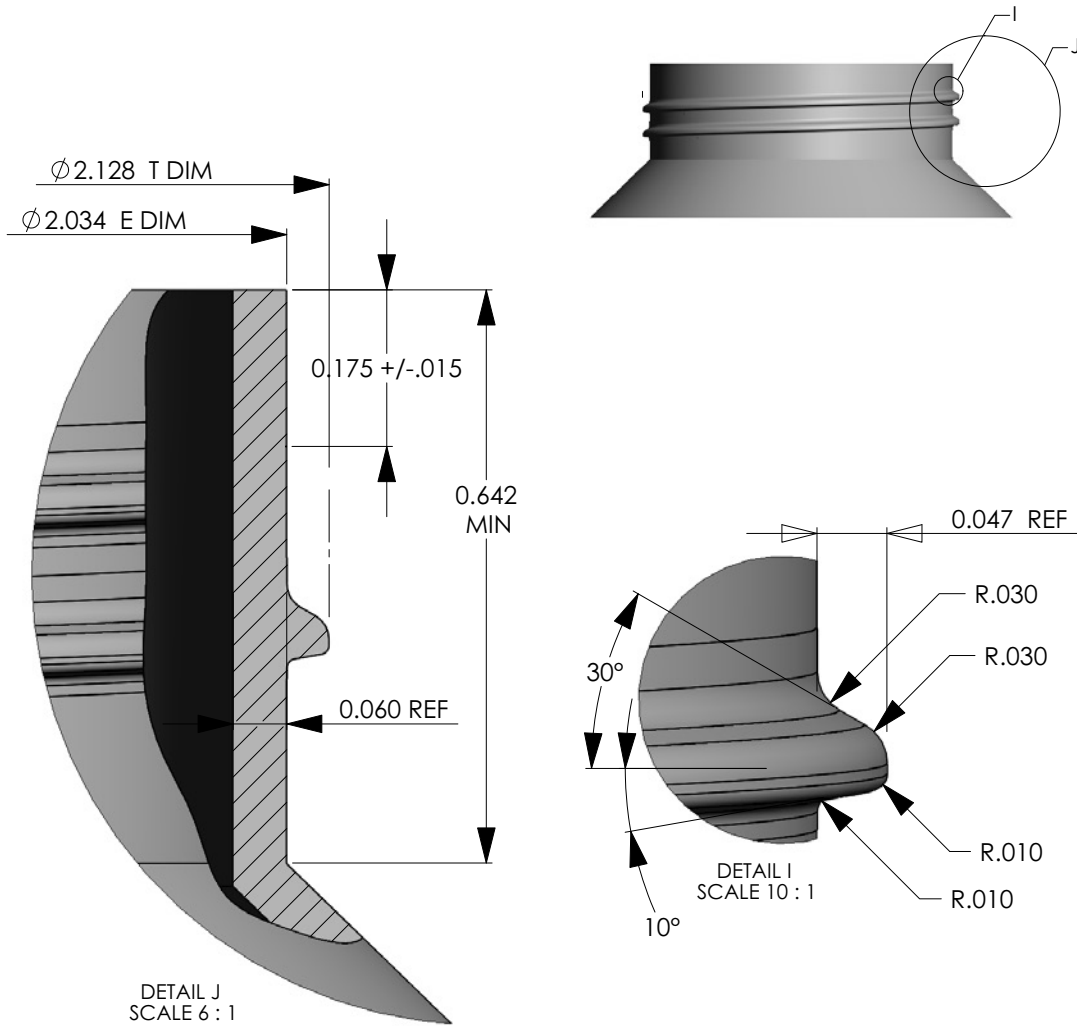

MATERIAL	T (mean)	E (mean)	TOLERANCE
PP / PE	2.128	2.034	± .0175
PET	2.128	2.034	± .012
GLASS	0.0000	0.0000	± 0.0000

NOTES: (UNLESS OTHERWISE SPECIFIED) 1. ALL DIMENSIONS ARE IN INCHES. 2. SEE CHART FOR DIMENSIONAL TOLERANCE.		0	01.14.05	Released	DN
REV	DATE	DESCRIPTION			BY
TOLERANCE		PITCH/TPI	1.67 / 6	TURNS	0-0/0
MATERIAL		XXX			
.X	±0.1	DRAWN	BEZ	DATE	01.14.05
.XX	±0.02	SCALE		2 : 1	REV
.XXX	±0.010	56 - 445 - FINISH			0



PHOENIX™

PHXPKG.COM

P 630 420 4750 E greatpkg@phxpkg.com
1899 High Grove Lane Naperville, IL 60540